

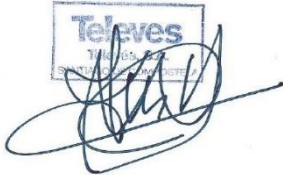

TEST REPORT

TEST REPORT	
Nombre del producto:	SPLITTERS, TAPS (5...2400 MHz)
Referencias	519502, 519503, 519504, 519505, 519506, 519508 519322, 519323, 519324, 519325 519341, 519342, 519343, 519344, 519345 519362, 519363, 519364, 519365 519382, 519383, 519384, 519385 519532, 519533, 519534, 519535, 519536
Preparado por:	Televes SAU B. de Conxo, 17 15706 Santiago de Compostela La Coruña - España
Fecha del test:	2 de mayo de 2023
Fecha del informe:	8 de mayo de 2023
Informe N°:	TVSP202305001

TEST REPORT**IEC 60728-4****Cable networks for television signals, sound signals and interactive services****Part 4: Passive wideband equipment for coaxial cable networks**

Nombre del Laboratorio	Televes SAU
Dirección	B. de Conxo 17, Santiago de Compostela, La Coruña, España
Ubicación del test	Santiago de Compostela
Empresa solicitante	Televes SAU
Dirección	B. de Conxo 17, Santiago de Compostela, La Coruña, España
Fabricante	Televes SAU
Dirección	B. de Conxo 17, Santiago de Compostela, La Coruña, España
Especificación del test	
Estándar	IEC – 60728 -4: 2007
Desviaciones al procedimiento de medida	N/A
Métodos de test no estándar	N/A
Descripción de los productos bajo test	SPLITTERS, TAPS
Marca de los productos	Televes
Modelos y referencias	Según Anexo C
Rating(s)	/
Resultados del test	
La cláusula no aplica al producto en cuestión N/A	
El producto en cuestión cumple el requisitoP(asa)	
El producto en cuestión no cumple el requisito N(o pasa)	

GENERAL REMARKS	REMARK
<p>Este informe no será reproducido ni en todo ni en parte sin el consentimiento por escrito del laboratorio que ha testado los productos.</p> <p>Los resultados del test de la IEC se corresponden a las muestras testadas.</p> <p>La serie de productos (repartidores) a los que se refiere este informe tienen la misma funcionalidad, repartir la señal de entrada a una multiplicidad de salidas. Son dispositivos pasivos y las diferencias entre ellos son exclusivamente el número de salidas.</p> <p>La serie de productos (derivadores) a los que se refiere este informe tienen la misma funcionalidad, repartir la señal de entrada a una multiplicidad de salidas con una de ellas con pérdidas de paso bajas (la salida denominada paso o thru). Son dispositivos pasivos y las diferencias entre ellos son exclusivamente el número de salidas.</p> <p>Se ha seleccionado un ítem de cada uno (repartidor, derivador) para el propósito del test</p>	
<p>Realizado por:</p> <p>J. Rodal</p>	
<p>Revisado y Aprobado por:</p> <p>M. Gómez</p>	 

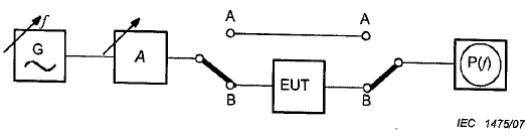
IEC-60728-4			
Cláusula	Requisito + Test	Comentarios	Resultado
4	Methods of measurements		P
4.1	Attenuation		P
4.1.1	Test equipment The following test equipment is required: <ul style="list-style-type: none"> • tuneable r.f. signal generator; • variable calibrated attenuator; • r.f. switch; • spectrum analyser or selective voltmeter. 	Tested with network analyzer. Tested value according data sheet specification.	P
4.1.2	Measurement procedure The equipment shall be connected as shown in Figure 1. Both r.f. switches shall be set to position A. The variable attenuator shall be adjusted until a reference line on the spectrum analyser or a reference value on the selective voltmeter is met. The value a1 in dB of the variable attenuator shall be read. Both r.f. switches shall be set to position B. The variable attenuator shall be adjusted until the reference (line) is met again. The value a2 in dB of the variable attenuator shall be read.  <p style="text-align: center;">IEC 1475/07</p> <p>Figure 1 - Test set-up for the measurement of attenuation</p> <p>The attenuation in dB of the EUT for the chosen frequency is $a1 - a2$. This procedure shall be repeated at all relevant frequencies for the EUT.</p>		P
4.1.3	Presentation of the results The attenuation of the EUT is expressed in dB, with reference to the chosen frequencies.		-
4.2	Isolation		P
4.2.1	Definition The isolation measured in dB is the attenuation ratio between two outputs of a component if the signal is inserted in one of these outputs		P
4.2.2	Test equipment The following test equipment is required: <ul style="list-style-type: none"> • tuneable RF signal generator; • variable calibrated attenuator; • spectrum analyser or selective voltmeter; • RF switch. 	Tested with network analyzer. Tested value according data sheet specification.	P

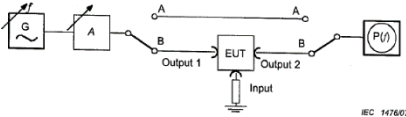
IEC-60728-4			
Cláusula	Requisito + Test	Comentarios	Resultado
4.2.3	<p>Measurement procedure</p> <p>The equipment shall be connected as shown in Figure 2. Both RF switches shall be set to position A. The variable attenuator shall be adjusted until a reference line on the spectrum analyser or a reference value on the selective voltmeter is met. The value a_1 in dB of the variable attenuator shall be read. Both RF switches shall be set to position B. The variable attenuator shall be adjusted until the reference line is met again. The value a_2 in dB of the variable attenuator shall be read. The signal shall be inserted into output port 2, the detector connected to output port 1 and the procedure repeated.</p>  <p style="text-align: center;">IEC 147607</p> <p>Figure 2 - Test set-up for the measurement of isolation</p> <p>The isolation in dB of the EUT for the chosen frequency is $a_1 - a_2$. This procedure shall be repeated at all relevant frequencies for the EUT.</p>		P
4.2.4	<p>Presentation of the results</p> <p>The isolation of the EUT is expressed in dB with reference to the chosen frequencies.</p>		-
4.3	Through-loss		P
4.3.1	<p>Definition</p> <p>The through-loss, measured in dB, is the difference in signal level between the input and the looped-through output of the equipment.</p>		P
4.3.2	<p>Test equipment</p> <p>The following test equipment is required:</p> <ul style="list-style-type: none"> • tuneable r.f. signal generator; • variable calibrated attenuator; • r.f. switch; • spectrum analyser or selective voltmeter. 	<p>Tested with network analyzer.</p> <p>Tested value according data sheet specification.</p>	P

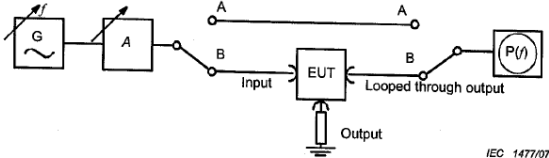
IEC-60728-4			
Cláusula	Requisito + Test	Comentarios	Resultado
4.3.3	<p>Measurement procedure</p> <p>The equipment shall be connected as shown in Figure 3. Both r.f. switches shall be set to position A. The variable attenuator shall be adjusted until a reference line on the spectrum analyser or a reference value on the selective voltmeter is met. The value a1 in dB of the variable attenuator shall be read. Both r.f. switches shall be set to position B. The variable attenuator shall be adjusted until the reference (line) is met again. The value a2 in dB of the variable attenuator shall be read.</p>  <p style="text-align: center;">IEC 1477/07</p> <p style="text-align: center;">Figure 3 - Measurement of through-loss</p> <p>The insertion loss in dB of the EUT for the chosen frequency is a1 - a2.</p>		P
4.3.4	<p>Presentation of the results</p> <p>The insertion loss of the EUT is expressed in dB, with reference to the chosen frequency.</p>		P
4.4	Group delay variation		P
4.4.1	<p>Definition</p> <p>Group delay variation is defined as the deviation from a linear phase-frequency response.</p>		P
4.4.2	<p>Test equipment</p> <p>A network analyser is required.</p>		P
4.4.3	<p>Method of measurement</p> <p>For the measurement of group delay, a network analyser shall be used. To ensure a reliable test result, the instructions of the test set manufacturer shall be met. The phase shift is expressed as group delay by means of the formula:</p> $\tau_g = \frac{\Delta\phi}{360^\circ \cdot f_m}$ <p>$\Delta\phi$ is the phase difference in degrees; f_m is the frequency of the test signal in Hertz; τ_g is the group delay in seconds.</p> <p>The group delay variation is determined by using the formula above or is read directly on the commercial measuring instrument.</p>	0.03s	P
4.4.4	<p>Presentation of the result</p> <p>The group delay variation is expressed in ns in the frequency range of the EUT.</p>		P

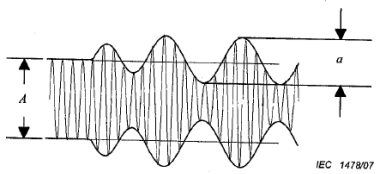
IEC-60728-4			
Cláusula	Requisito + Test	Comentarios	Resultado
4.5	Amplitude frequency response For the measurement method of amplitude frequency response, see 4.1. The amplitude response of an equipment or system is presented as a1 - a2 , plotted against frequency.		P
4.6	Return loss Return-loss measurements shall be carried out as laid down in IEC 60728-3. Unused ports shall be well-matched in 75 Q or open/shorted if required.	open/shorted if required	P
4.7	Hum modulation of carrier		P
4.7.1	<p>Definition</p> <p>The interference ratio for hum modulation is the ratio stated in dB between the peak-to-peak value of the unmodulated carrier and the peak-to-peak variation a of the envelope around the carrier A caused by the hum modulating this carrier, i.e.</p> $\text{carrier/hum ratio} = 20 \lg \frac{A}{a} \text{ [dB]}$  <p>Figure 4 - Carrier/hum ratio</p>		P
4.7.2	Description of the method of measurement		P
4.7.2.1	<p>General</p> <p>This measurement method is valid for radio and TV signal equipment within a cable network that is supplied with 50 Hz a.c..</p> <p>For measuring purposes, sinusoidal signals are used. Taking into account the maximum admissible voltage or the maximum admissible current, the worst value for the operating frequency range shall be published.</p>	50 Hz a.c	P

IEC-60728-4			
Cláusula	Requisito + Test	Comentarios	Resultado
4.7.2.2	<p>Test equipment</p> <p>The following test equipment is required:</p> <ul style="list-style-type: none"> • adjustable voltage source; • variable load resistor; • power inserter; • variable calibrated attenuator; • oscilloscope; • voltmeter (r.m.s.); • ampere meter; • tuneable r.f. signal generator with sufficient phase-noise and hum-modulation ratio, including AM capability (400 Hz); • detector including (battery-powered) low-frequency amplifier and 1 kHz LP filter in the output, to suppress low-frequency distortion (an HP-filter at the input shall be used). 	Tuneable r.f. signal generator	P
4.7.2.3	<p>Connection of test equipment</p> <p>The connection scheme for locally powered EUT is shown in Figure 5; the connection scheme for remotely powered EUT is shown in Figure 6.</p> <p style="text-align: right;"><small>IEC 1479/07</small></p> <p style="text-align: center;">Figure 5 – Test set-up for power injectors</p> <p style="text-align: right;"><small>IEC 1480/07</small></p> <p style="text-align: center;">Figure 6 – Test set-up for passive equipment, excluding power injectors</p>		P

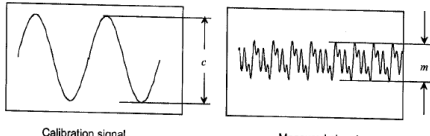
IEC-60728-4			
Cláusula	Requisito + Test	Comentarios	Resultado
4.7.3	Measuring procedure		P
4.7.3.1	<p>Set-up of calibration</p> <p>The reference signal is generated by means of the RF signal generator shown in Figure 5 and Figure 6. An r.f. carrier frequency that suits the TV channel under consideration shall be chosen and modulated to a depth of 1 % at a frequency of 400 Hz. The r.f. signal generator shall be adjusted to an appropriate level and the peak-to-peak value of the demodulated AM signal (c in Figure 7) read on the oscilloscope. This is the reference signal. With 1 % modulation this value is: $-20 \lg (0,01) = 40 \text{ dB (6)}$</p> <p>The modulation of the signal generator shall be switched off. The remaining value, m, in Figure 7 is the value to be measured.</p>  <p>Figure 7. Oscilloscope display</p> <p>The suitability of the measuring set-up shall be checked by connecting points A and B together and measuring the inherent hum of the set-up. The calculation of the hum-modulation ratio is given in 4.7.4. This value should be at least 10 dB better than the values to be measured on items of equipment. For measurements with set-up for locally powered EUT, the set-up shown in Figure 5 shall be used for check. The subsequent measurements shall be carried out in suitable increments through the entire operating frequency range. The measured value is independent of the r.f. level; however, the r.f. level should be at least the magnitude of the EUT operating level.</p>		P

IEC-60728-4			
Cláusula	Requisito + Test	Comentarios	Resultado
4.7.3.2	<p>Locally powered EUT</p> <p>The EUT shall be adjusted to maximum or minimum operating voltage using the transformer.</p> <p>The supply current depends on the power requirement of the EUT.</p> <p>The signal generator shall be modulated with the reference signal and the level at point B shall be adjusted by means of an attenuator in such a way that neither the EUT is overdriven nor the detector is within a non-admissible operating range. The peak-to-peak amplitude, c, of the demodulated reference signal, which is displayed on the oscilloscope, shall be noted. Then the reference signal shall be switched off and the peak-to-peak value, m, of the remaining signal measured.</p> <p>In addition, for EUT with remote supply terminals, the maximum admissible peak current for the respective terminal shall be adjusted by means of resistor R.</p>	The peak-to-peak amplitude	P
4.7.3	<p>Remotely supplied EUT</p> <p>For remotely supplied EUT, the general procedure described in 4.7.3.2 shall be followed. The only difference is that the supply energy is routed to the equipment via an r.f. terminal. In the case where there are several r.f. interfaces available for power insertion, each of these interfaces shall be included in the measurement procedure in a suitable manner.</p>		P
4.7.4	Calculating the hum-modulation ratio		P
4.7.4.1	<p>Frequency range</p> <p>The frequency range considered for the hum is from 50 Hz to 1 kHz.</p>		P
4.7.4.2	<p>Individual EUT</p> <p>The hum-modulation ratio [EUT] is equal to $40 \text{ dB} + 20 \lg(c/m) \text{ [dB]}$ for 1 % reference modulation depth.</p> <p>For other chosen reference modulation depths, the value 40 dB shall be replaced by the result of the term $- 20 \lg(\text{modulation depth})$.</p>	40 dB	P

4.7.4.3	<p>Cascaded EUT</p> <p>For high hum-modulation ratios, it can be useful to cascade several EUT for better determination of the measuring values. Then, to calculate the individual EUT, the following formula shall be used.</p> <p>Hum-modulation ratio [EUT] = Hum-modulation ratio [cascaded] +20 lg n [dB]</p> <p>where “n” is the number of cascaded EUT.</p>		P
---------	--	--	---

IEC-60728-4			
Cláusula	Requisito + Test	Comentarios	Resultado
4.7.4.4	Loop-value correction If a set-up calibration correction is required, the following formula shall be used.		P
4.7.4.5	Presentation of the results The hum-modulation ratio is expressed in dB.		P

IEC-60728-4			
Cláusula	Requisito + Test	Comentarios	Resultado
4.8	<p>Two-carrier intermodulation measurements for second- and third-order products</p> <p>Splitters, taps and directional couplers contain ferrite transformers. These transformers are non-linear and produce harmonic and intermodulation products. These are predominately third-order products and are insignificant (greater than 120 dBc), providing the ferrite cores are not magnetised. If the cores become magnetized then significant second-order products may be produced. Third harmonic products remain low.</p> <p>Ferrite transformers saturate easily when subjected to d.c. or pulse voltages. A typical splitter input transformer will saturate in less than 10 V/ μs. It is not possible to stop equipment becoming magnetized in the CATV environment. In order to carry out harmonic or intermodulation tests, it is therefore necessary to magnetize equipment prior to test in order to simulate worst-case conditions. The surge immunity test described in 5.1.6.2 provides adequate magnetization and may be used to precondition the equipment under test. As an alternative to the surge immunity test, a 25 V/500 μs pulse should be applied to each port via a 300 Ω source impedance prior to testing.</p> <p>In circuits each ferrite core appears as a coherent harmonic generator with a source impedance determined by the relevant circuit elements. It is thus imperative that all of the equipment ports are correctly terminated at all frequencies to enable correct measurements to be taken.</p> <p>Following this saturation, the core will remain magnetized. For splitters and taps, the return path signal is applied to each output port OP x and measurements are taken at either or both output ports via diplex filters (see Figure 8). The harmonic signal present at the input port IP is of no significance.</p>		P

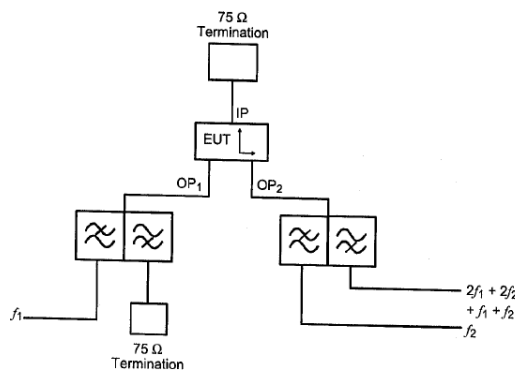
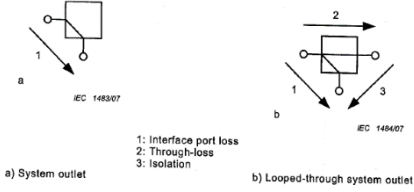

Figure 8 - Harmonic/Intermodulation test circuit

IEC-60728-4			
Cláusula	Requisito + Test	Comentarios	Resultado
5.1	General performance requirements and recommendations		P
5.1.1	Safety The relevant safety requirements as laid down in IEC 60728-11 shall be met.		P
5.1.2	Electromagnetic compatibility (EMC) The relevant EMC requirements laid down in IEC 60728-2 shall be met. The EMC class A or B shall be published. It is recommended that "Class A" or "Class B" be indicated on the product.	Class A	P
5.1.3	Environmental Manufacturers shall publish relevant environmental information on their products in accordance with the requirements of the following publications. Storage (simulated effects of) IEC 60068-2-48 Transportation Air freight (combined cold and low pressure) IEC 60068-2-40 Road transport (bump test) IEC 60068-2-29 Road transport (shock test) IEC 60068-2-27 Installation or maintenance Tumble or drop test IEC 60068-2-31 Free fall test IEC 60068-2-32 Operation IP Class. Protection provided by enclosures IEC 60529 Climatic category of component or equipment for storage and operation as defined in Annex A of IEC 60068-1 Cold IEC 60068-2-1 Dry heat IEC 60068-2-2 Damp heat IEC 60068-2-30 Change of temperature (Test Nb) IEC 60068-2-14 Vibration (sinusoidal) Annex B of IEC 60068-2-6		-
5.1.4	Marking		P
5.1.4.1	Marking of equipment Each piece of equipment shall be legibly and durably marked with the manufacturer's name and type number.		P
5.1.4.2	Marking of ports It is recommended that symbols in accordance with IEC 60417 should be used when marking ports.		P
5.1.5	Impedance The nominal impedance of all passive equipment shall be 75 Ohm.		P
5.1.6	Degradation of performance caused by overvoltages		P

IEC-60728-4			
Cláusula	Requisito + Test	Comentarios	Resultado
5.1.6.1	<p>Introduction</p> <p>Surges caused by overvoltages from switching and lightning transients may degrade the performance of passive equipment.</p> <p>For products with surge protection the manufacturer shall indicate "surge-proof" in the product information and in the data sheet. For this equipment, the following requirements shall be met.</p>		P
5.1.6.2	<p>Surge immunity</p> <p>Passive equipment used at the subscriber premises and the spur feeder shall comply with performance criterion B (according to IEC 61000-6-1) after a surge voltage of 1 kV according to IEC 61000-4-5 (class 2, test level 2) has been applied. It shall be applied between the inner and the outer conductor of each port.</p>	1 kV	P
5.1.6.3	<p>Degradation of intermodulation performance</p> <p>After the test according to 5.1.6.2, the intermodulation requirements as specified in 5.3.4.8 (system outlets) and 5.4.3.10 (splitters and taps) should still be met.</p>		P
5.2	<p>Performance requirements and recommendations for receiver lead</p> <p>The performance requirements and recommendations for receiver leads are stated in IEC 60966-1, IEC 60966-2-4, IEC 60966-2-5 and IEC 60966-2-6</p>		P
5.3	<p>Performance requirements and recommendations for system outlets</p>		P
5.3.1	<p>Safety</p> <p>Safety isolation can be incorporated in the system outlet and may be a requirement of local regulations. The isolation shall meet the requirements of IEC 60728-11 for isolated system outlets.</p>		P
5.3.2	<p>Quality grading</p> <p>There is only one quality grade.</p>		P
5.3.3	<p>Mechanical requirements</p>		P
5.3.3.1	<p>Conduit box</p> <p>The system outlet shall be compatible with the conduit box used, which may be nationally or internationally standardized.</p>		P
5.3.3.2	<p>Interface ports</p> <p>An IEC 61169-2 male connector shall be used for the TV interface port. An IEC 61169-2 female connector shall be used for the radio interface port.</p> <p>These connectors shall conform to IEC 61169-1. As an alternative, female F-connectors in accordance with IEC 61169-24 may be used.</p>		P
5.3.4	<p>Electrical parameters and requirements</p>		P

IEC-60728-4																																																																								
Cláusula	Requisito + Test	Comentarios	Resultado																																																																					
5.3.4.1	<p>Definitions</p> <p>For outlets with integral filters, a relaxation of 3 dB in return loss and isolation requirements is permissible in the pass-band edges. The pass-band edge is defined to be 8 MHz above the lower and 8 MHz below the upper cut-off frequencies for AM-TV and, respectively, 30 MHz for FM-TV, 4 MHz for FM-radio and 2 MHz for return path.</p>		p																																																																					
5.3.4.2	<p>Return loss</p> <p>The minimum return loss shall be according to Table 1 and Table 2.</p> <p style="text-align: center;">Table 1 – Return loss of system outlets</p> <table border="1"> <thead> <tr> <th>Port</th> <th>Frequency range</th> <th>Requirement</th> </tr> </thead> <tbody> <tr> <td rowspan="4">Input</td> <td>5 MHz to 10 MHz</td> <td>Shall be published</td> </tr> <tr> <td>10 MHz to 47 MHz</td> <td>≥14 dB</td> </tr> <tr> <td>47 MHz to 950 MHz</td> <td>≥(14 dB – 1.5 dB/octave) but ≥10 dB ≥10 dB in 87.5 to 108 MHz range</td> </tr> <tr> <td>950 MHz to 3 000 MHz</td> <td>≥10 dB decreasing linearly to 6 dB</td> </tr> <tr> <td>TV</td> <td>47 MHz to 950 MHz</td> <td>≥(14 dB – 1.5 dB/octave), but ≥10 dB^a</td> </tr> <tr> <td>FM radio</td> <td>87.5 MHz to 108 MHz</td> <td>≥10 dB</td> </tr> <tr> <td rowspan="4">RF data</td> <td>5 MHz to 10 MHz</td> <td>Shall be published</td> </tr> <tr> <td>10 MHz to 47 MHz</td> <td>≥14 dB</td> </tr> <tr> <td>47 MHz to 950 MHz</td> <td>≥(14 dB – 1.5 dB/octave) but ≥10 dB</td> </tr> <tr> <td>950 MHz to 3 000MHz</td> <td>≥10 dB decreasing linearly to 6 dB</td> </tr> <tr> <td>Satellite</td> <td>950 MHz to 3 000 MHz</td> <td>≥10 dB decreasing linearly to 6 dB</td> </tr> </tbody> </table> <p>^a Recommended minimum value 10 dB up to 950 MHz. NOTE The specifications in Table 1 are not applicable for system outlets in Japan (see Clause B.3).</p> <p style="text-align: center;">Table 2 – Return loss of looped-through system outlets</p> <table border="1"> <thead> <tr> <th>Port</th> <th>Frequency range</th> <th>Requirement</th> </tr> </thead> <tbody> <tr> <td rowspan="4">Input</td> <td>5 MHz to 10 MHz</td> <td>Shall be published</td> </tr> <tr> <td>10 MHz to 47 MHz</td> <td>≥18 dB</td> </tr> <tr> <td>47 MHz to 950 MHz</td> <td>≥(18 dB – 1.5 dB/octave)</td> </tr> <tr> <td>950 MHz to 3 000 MHz</td> <td>≥10 dB decreasing linearly to 6 dB</td> </tr> <tr> <td rowspan="4">Output (looped through)</td> <td>5 MHz to 10 MHz</td> <td>Shall be published</td> </tr> <tr> <td>10 MHz to 47 MHz</td> <td>≥18 dB</td> </tr> <tr> <td>47 MHz to 950 MHz</td> <td>≥(18 dB – 1.5 dB/octave)</td> </tr> <tr> <td>950 MHz to 3 000 MHz</td> <td>≥10 dB decreasing linearly to 6 dB</td> </tr> <tr> <td>TV</td> <td>47 MHz to 950 MHz</td> <td>≥(14 dB – 1.5 dB/octave), but ≥10 dB</td> </tr> <tr> <td>FM radio</td> <td>87.5 MHz to 108 MHz</td> <td>≥10 dB</td> </tr> <tr> <td rowspan="4">RF data</td> <td>5 MHz to 10 MHz</td> <td>Shall be published</td> </tr> <tr> <td>10 MHz to 47 MHz</td> <td>≥14 dB</td> </tr> <tr> <td>47 MHz to 950 MHz</td> <td>≥(14 dB – 1.5 dB/octave) but ≥10 dB</td> </tr> <tr> <td>950 MHz to 3 000MHz</td> <td>≥10 dB decreasing linearly to 6 dB</td> </tr> <tr> <td>Satellite</td> <td>950 MHz to 3 000 MHz</td> <td>≥10 dB decreasing linearly to 6 dB</td> </tr> </tbody> </table> <p>NOTE 1 The specifications in Table 2 are not applicable for system outlets in Japan (see Clause B.3). NOTE 2 For requirements in the Netherlands, see Clause B.2</p>	Port	Frequency range	Requirement	Input	5 MHz to 10 MHz	Shall be published	10 MHz to 47 MHz	≥14 dB	47 MHz to 950 MHz	≥(14 dB – 1.5 dB/octave) but ≥10 dB ≥10 dB in 87.5 to 108 MHz range	950 MHz to 3 000 MHz	≥10 dB decreasing linearly to 6 dB	TV	47 MHz to 950 MHz	≥(14 dB – 1.5 dB/octave), but ≥10 dB ^a	FM radio	87.5 MHz to 108 MHz	≥10 dB	RF data	5 MHz to 10 MHz	Shall be published	10 MHz to 47 MHz	≥14 dB	47 MHz to 950 MHz	≥(14 dB – 1.5 dB/octave) but ≥10 dB	950 MHz to 3 000MHz	≥10 dB decreasing linearly to 6 dB	Satellite	950 MHz to 3 000 MHz	≥10 dB decreasing linearly to 6 dB	Port	Frequency range	Requirement	Input	5 MHz to 10 MHz	Shall be published	10 MHz to 47 MHz	≥18 dB	47 MHz to 950 MHz	≥(18 dB – 1.5 dB/octave)	950 MHz to 3 000 MHz	≥10 dB decreasing linearly to 6 dB	Output (looped through)	5 MHz to 10 MHz	Shall be published	10 MHz to 47 MHz	≥18 dB	47 MHz to 950 MHz	≥(18 dB – 1.5 dB/octave)	950 MHz to 3 000 MHz	≥10 dB decreasing linearly to 6 dB	TV	47 MHz to 950 MHz	≥(14 dB – 1.5 dB/octave), but ≥10 dB	FM radio	87.5 MHz to 108 MHz	≥10 dB	RF data	5 MHz to 10 MHz	Shall be published	10 MHz to 47 MHz	≥14 dB	47 MHz to 950 MHz	≥(14 dB – 1.5 dB/octave) but ≥10 dB	950 MHz to 3 000MHz	≥10 dB decreasing linearly to 6 dB	Satellite	950 MHz to 3 000 MHz	≥10 dB decreasing linearly to 6 dB		p
Port	Frequency range	Requirement																																																																						
Input	5 MHz to 10 MHz	Shall be published																																																																						
	10 MHz to 47 MHz	≥14 dB																																																																						
	47 MHz to 950 MHz	≥(14 dB – 1.5 dB/octave) but ≥10 dB ≥10 dB in 87.5 to 108 MHz range																																																																						
	950 MHz to 3 000 MHz	≥10 dB decreasing linearly to 6 dB																																																																						
TV	47 MHz to 950 MHz	≥(14 dB – 1.5 dB/octave), but ≥10 dB ^a																																																																						
FM radio	87.5 MHz to 108 MHz	≥10 dB																																																																						
RF data	5 MHz to 10 MHz	Shall be published																																																																						
	10 MHz to 47 MHz	≥14 dB																																																																						
	47 MHz to 950 MHz	≥(14 dB – 1.5 dB/octave) but ≥10 dB																																																																						
	950 MHz to 3 000MHz	≥10 dB decreasing linearly to 6 dB																																																																						
Satellite	950 MHz to 3 000 MHz	≥10 dB decreasing linearly to 6 dB																																																																						
Port	Frequency range	Requirement																																																																						
Input	5 MHz to 10 MHz	Shall be published																																																																						
	10 MHz to 47 MHz	≥18 dB																																																																						
	47 MHz to 950 MHz	≥(18 dB – 1.5 dB/octave)																																																																						
	950 MHz to 3 000 MHz	≥10 dB decreasing linearly to 6 dB																																																																						
Output (looped through)	5 MHz to 10 MHz	Shall be published																																																																						
	10 MHz to 47 MHz	≥18 dB																																																																						
	47 MHz to 950 MHz	≥(18 dB – 1.5 dB/octave)																																																																						
	950 MHz to 3 000 MHz	≥10 dB decreasing linearly to 6 dB																																																																						
TV	47 MHz to 950 MHz	≥(14 dB – 1.5 dB/octave), but ≥10 dB																																																																						
FM radio	87.5 MHz to 108 MHz	≥10 dB																																																																						
RF data	5 MHz to 10 MHz	Shall be published																																																																						
	10 MHz to 47 MHz	≥14 dB																																																																						
	47 MHz to 950 MHz	≥(14 dB – 1.5 dB/octave) but ≥10 dB																																																																						
	950 MHz to 3 000MHz	≥10 dB decreasing linearly to 6 dB																																																																						
Satellite	950 MHz to 3 000 MHz	≥10 dB decreasing linearly to 6 dB																																																																						
5.3.4.3	<p>Frequency range</p> <p>The operating frequency range of the system outlet shall be published.</p>		P																																																																					

IEC-60728-4																	
Cláusula	Requisito + Test	Comentarios	Resultado														
5.3.4.4	<p>Losses The nominal attenuation and its tolerance for</p> <ul style="list-style-type: none"> • interface port loss; • through loss; • isolation, <p>as defined in Figure 9, shall be published.</p>  <p style="text-align: center;">Figure 9 - Types of losses of system outlets</p>		P														
5.3.4.5	<p>Amplitude frequency response flatness The flatness of the amplitude frequency response from the input port to all other ports shall be published. Peak-to-peak narrowband flatness to the output port/s (looped-through only) shall be within 0,2 dB in a band of 0,5 MHz and 0,5 dB in a band of 7 MHz.</p>		P														
5.3.4.6	<p>Isolation between interface ports All system outlets shall meet the following requirements. The minimum attenuation between TV and radio interface ports shall be 10 dB over the operating frequency range. The minimum attenuation between broadband interface ports shall be 20 dB over the operating frequency range. Where filters are incorporated in the system outlet, the selectivity shall be published.</p>	20 dB	P														
5.3.4.7	<p>Group delay variation Shall be published.</p>		N/A														
5.3.4.8	<p>Intermodulation in system outlets On the basis of the test method described in 4.8, it is required that the manufacturer shall specify the maximum return path signal level [dB(pV)] according to Table 3. This requirement is valid before and after the test with overvoltages (see 5.1.6).</p> <p style="text-align: center;">Table 3 – Maximum return path signal level derived from maximum allowed intermodulation distortion level in the downstream frequency band</p> <table border="1" style="margin-left: auto; margin-right: auto;"> <thead> <tr> <th></th> <th>Test frequency in MHz</th> <th>Max. level in dB(μV)</th> </tr> </thead> <tbody> <tr> <td rowspan="2">Return path (upstream)</td> <td>$f_1 = 60$</td> <td rowspan="2">Shall be specified</td> </tr> <tr> <td>$f_2 = 65$</td> </tr> <tr> <td rowspan="3">Distribution (downstream)</td> <td>$2f_1 = 120$</td> <td>≤ 15</td> </tr> <tr> <td>$f_1 + f_2 = 125$</td> <td>≤ 15</td> </tr> <tr> <td>$2f_2 = 130$</td> <td>≤ 15</td> </tr> </tbody> </table>		Test frequency in MHz	Max. level in dB(μV)	Return path (upstream)	$f_1 = 60$	Shall be specified	$f_2 = 65$	Distribution (downstream)	$2f_1 = 120$	≤ 15	$f_1 + f_2 = 125$	≤ 15	$2f_2 = 130$	≤ 15		N/A
	Test frequency in MHz	Max. level in dB(μV)															
Return path (upstream)	$f_1 = 60$	Shall be specified															
	$f_2 = 65$																
Distribution (downstream)	$2f_1 = 120$	≤ 15															
	$f_1 + f_2 = 125$	≤ 15															
	$2f_2 = 130$	≤ 15															
5.4	<p>Performance requirements and recommendations for splitters and taps</p>		P														

IEC-60728-4																										
Cláusula	Requisito + Test	Comentarios	Resultado																							
5.4.1	<p>Description</p> <p>Splitters and taps are used in the coaxial cable network and the subscriber network. A splitter divides the signal power at the input port equally or unequally between two or more (output) ports. A tap contains, in addition to its input and output ports, one or more tap ports.</p> <p>A subscriber tap provides the principal isolation between subscribers. There are three quality grades.</p> <p>Taps and splitters may incorporate an a.c. or a d.c. bypass.</p>	The grade of the equipment shall be published.	P																							
5.4.2	<p>Mechanical requirements for connectors</p> <p>The type of cable connection used shall be published.</p>		P																							
5.4.3	Electrical parameters and requirements		P																							
5.4.3.1	<p>Return loss</p> <p>The minimum return loss for the specified grade shall be according to Table 4.</p> <p style="text-align: center;">Table 4 - Return loss of splitters and taps</p> <table border="1" style="width: 100%; border-collapse: collapse;"> <thead> <tr> <th rowspan="2">Frequency range</th> <th colspan="3">Requirement</th> </tr> <tr> <th>Grade 1</th> <th>Grade 2</th> <th>Grade 3</th> </tr> </thead> <tbody> <tr> <td>5 MHz to 10 MHz</td> <td>Shall be published</td> <td>Shall be published</td> <td>Shall be published</td> </tr> <tr> <td>10 MHz to 47 MHz</td> <td>*22 dB</td> <td>*18 dB</td> <td>■ 14 dB</td> </tr> <tr> <td>47 MHz to 950 MHz</td> <td>>(22 dB- 1,5 dB/octave)</td> <td>>(18 dB - 1,5 dB/octave)</td> <td>*(14 dB - 1,5 dB/octave) but *10 dB</td> </tr> <tr> <td>950 MHz to 3 000 MHz</td> <td>>14 dB decreasing linearly to 10 dB</td> <td>>10 dB decreasing linearly to 6 dB</td> <td>>10 dB decreasing linearly to 6 dB</td> </tr> </tbody> </table> <p>NOTE The specifications in Table 4 are not applicable for splitters and taps in Japan (see Clause B.4).</p> <p>For subscriber taps of grade 1 and grade 2, the input return loss in the frequency range from 10 MHz to 950 MHz shall be at least 10 dB, decreasing linearly to 6 dB at 3 000 MHz, with the interface ports either open- or short-circuited.</p>	Frequency range	Requirement			Grade 1	Grade 2	Grade 3	5 MHz to 10 MHz	Shall be published	Shall be published	Shall be published	10 MHz to 47 MHz	*22 dB	*18 dB	■ 14 dB	47 MHz to 950 MHz	>(22 dB- 1,5 dB/octave)	>(18 dB - 1,5 dB/octave)	*(14 dB - 1,5 dB/octave) but *10 dB	950 MHz to 3 000 MHz	>14 dB decreasing linearly to 10 dB	>10 dB decreasing linearly to 6 dB	>10 dB decreasing linearly to 6 dB	Meet	P
Frequency range	Requirement																									
	Grade 1	Grade 2	Grade 3																							
5 MHz to 10 MHz	Shall be published	Shall be published	Shall be published																							
10 MHz to 47 MHz	*22 dB	*18 dB	■ 14 dB																							
47 MHz to 950 MHz	>(22 dB- 1,5 dB/octave)	>(18 dB - 1,5 dB/octave)	*(14 dB - 1,5 dB/octave) but *10 dB																							
950 MHz to 3 000 MHz	>14 dB decreasing linearly to 10 dB	>10 dB decreasing linearly to 6 dB	>10 dB decreasing linearly to 6 dB																							
5.4.3.2	<p>Frequency range</p> <p>The operating frequency range shall be published.</p>		P																							
5.4.3.3	<p>Splitter loss</p> <p>The nominal attenuation between input port and output port/s, and its tolerance, shall be published.</p>		P																							
5.4.3.4	<p>Tap loss</p> <p>The nominal attenuation between input port and tap port/s, and its tolerance, shall be published.</p>		P																							
5.4.3.5	<p>Through-loss (taps only)</p> <p>The nominal attenuation between input port and output port, and its tolerance, shall be published.</p>		P																							
5.4.3.6	<p>Amplitude frequency response flatness</p> <p>The flatness of amplitude frequency response from the input to output and tap ports shall be published.</p> <p>Narrowband peak-to-peak flatness at the output port shall be within 0,2 dB in a band of 0,5 MHz and 0,5 dB in a band of 7 MHz.</p>		P																							
5.4.3.7	<p>Group delay variation</p> <p>Shall be published.</p>		P																							
5.4.3.8	<p>Hum modulation</p> <p>For equipment incorporating an a.c. bypass, the value of the hum modulation shall be published in dB at the worst case of powering current of the equipment.</p>		P																							

IEC-60728-4																										
Cláusula	Requisito + Test	Comentarios	Resultado																							
5.4.3.9	Isolation		P																							
5.4.3.9.1	<p>Splitters</p> <p>The isolation between all (output) ports shall be according to Table 5.</p> <p style="text-align: center;">Table 5 - Isolation of splitters</p> <table border="1"> <thead> <tr> <th rowspan="2">Frequency range</th> <th colspan="3">Requirement</th> </tr> <tr> <th>Grade 1</th> <th>Grade 2</th> <th>Grade 3</th> </tr> </thead> <tbody> <tr> <td>5 MHz to 10 MHz to MHz (o 47 MHz)</td> <td>Shall be published >22 dB</td> <td>Shall be published £13 dB</td> <td>Shall be published £14 dB</td> </tr> <tr> <td>47 MHz to 950 MHz</td> <td>£(22 dB - 1,5 dB/Octave)</td> <td>5(1 S dB - 1,5 dB/octave)</td> <td>>(14 dB - 1,5 dB/octave) but >10 dB</td> </tr> <tr> <td>950 MHz to 3 000 MHz</td> <td>>14 dB decreasing linearly to 10 dB</td> <td>>10 dB decreasing linearly to 6 dB</td> <td>>10 dB decreasing linearly to 6 dB</td> </tr> </tbody> </table> <p>NOTE The specifications in Table 5 are not applicable for splitters in Japan (see Clause B.4).</p>	Frequency range	Requirement			Grade 1	Grade 2	Grade 3	5 MHz to 10 MHz to MHz (o 47 MHz)	Shall be published >22 dB	Shall be published £13 dB	Shall be published £14 dB	47 MHz to 950 MHz	£(22 dB - 1,5 dB/Octave)	5(1 S dB - 1,5 dB/octave)	>(14 dB - 1,5 dB/octave) but >10 dB	950 MHz to 3 000 MHz	>14 dB decreasing linearly to 10 dB	>10 dB decreasing linearly to 6 dB	>10 dB decreasing linearly to 6 dB	Specified	P				
Frequency range	Requirement																									
	Grade 1	Grade 2	Grade 3																							
5 MHz to 10 MHz to MHz (o 47 MHz)	Shall be published >22 dB	Shall be published £13 dB	Shall be published £14 dB																							
47 MHz to 950 MHz	£(22 dB - 1,5 dB/Octave)	5(1 S dB - 1,5 dB/octave)	>(14 dB - 1,5 dB/octave) but >10 dB																							
950 MHz to 3 000 MHz	>14 dB decreasing linearly to 10 dB	>10 dB decreasing linearly to 6 dB	>10 dB decreasing linearly to 6 dB																							
5.4.3.9.2	<p>Taps</p> <p>The manufacturer shall publish the figures for isolation (between output and tap(s), or between all taps).</p>		P																							
5.4.3.10	<p>Intermodulation in splitters and taps</p> <p>The manufacturer shall specify the maximum return path signal. For the requirements, see 5.3.4.8</p>		P																							
5.5	Performance requirements and recommendations for all other passive equipment		P																							
5.5.1	<p>Description</p> <p>These equipment include</p> <ul style="list-style-type: none"> • transfer points; • power injectors; • cable splices; • galvanic isolators; • terminating resistors; • filters; • equalizers. <p>The quality grade shall be published.</p>	Meet	P																							
5.5.2	<p>Mechanical requirements for connectors</p> <p>The type of cable connection used shall be published.</p>		P																							
5.5.3	Electrical parameters and requirements		P																							
5.5.3.1	<p>Return loss</p> <p>The minimum return loss for the specified grade shall be according to Table 6.</p> <p style="text-align: center;">Table 6 - Return loss for all other passive equipment</p> <table border="1"> <thead> <tr> <th rowspan="2">Frequency range</th> <th colspan="3">Requirement</th> </tr> <tr> <th>Grade 1</th> <th>Grade 2</th> <th>Grade 3</th> </tr> </thead> <tbody> <tr> <td>5 MHz to 10 MHz</td> <td>Shall be published</td> <td>Shall be published</td> <td>Shall be published</td> </tr> <tr> <td>10 MHz to 47 MHz</td> <td>>22 dB</td> <td>>18 dB</td> <td>>14 dB</td> </tr> <tr> <td>47 MHz to 950 MHz</td> <td>£(22 dB - 1,5 dB/octave)</td> <td>£(18 dB 1,5 dB/octava)</td> <td>>(14 dB - 1,5 dB/octave) bui >10 dB</td> </tr> <tr> <td>950 MHz to 3 000 MHz</td> <td>14 dB decreasing linearly to 10 dB</td> <td>10 dB decreasing linearly to 6 dB</td> <td>10 dB decreasing linearly to 6 dB</td> </tr> </tbody> </table> <p>NOTE The specifications in Table 6 are not applicable for other passive equipment in Japan (see Clause B.5).</p>	Frequency range	Requirement			Grade 1	Grade 2	Grade 3	5 MHz to 10 MHz	Shall be published	Shall be published	Shall be published	10 MHz to 47 MHz	>22 dB	>18 dB	>14 dB	47 MHz to 950 MHz	£(22 dB - 1,5 dB/octave)	£(18 dB 1,5 dB/octava)	>(14 dB - 1,5 dB/octave) bui >10 dB	950 MHz to 3 000 MHz	14 dB decreasing linearly to 10 dB	10 dB decreasing linearly to 6 dB	10 dB decreasing linearly to 6 dB		P
Frequency range	Requirement																									
	Grade 1	Grade 2	Grade 3																							
5 MHz to 10 MHz	Shall be published	Shall be published	Shall be published																							
10 MHz to 47 MHz	>22 dB	>18 dB	>14 dB																							
47 MHz to 950 MHz	£(22 dB - 1,5 dB/octave)	£(18 dB 1,5 dB/octava)	>(14 dB - 1,5 dB/octave) bui >10 dB																							
950 MHz to 3 000 MHz	14 dB decreasing linearly to 10 dB	10 dB decreasing linearly to 6 dB	10 dB decreasing linearly to 6 dB																							

IEC-60728-4			
Cláusula	Requisito + Test	Comentarios	Resultado
5.5.3.2	<p>Frequency range The operating frequency range shall be published. For equipment with integral filters, a relaxation of 3 dB in return loss and isolation is permissible in the pass-band edges. The pass-band edge is defined to be 8 MHz above the lower and 8 MHz below the upper cut-off frequency for AM-TV and, respectively, 30 MHz for FM-TV, 4 MHz for FM radio and 2 MHz for return path.</p>		P
5.5.3.3	<p>Insertion loss The insertion loss and its tolerances shall be published.</p>		P
5.5.3.4	<p>Amplitude frequency response flatness The flatness of the amplitude frequency response between input and output ports shall be published. Narrowband peak-to-peak flatness shall be within 0,2 dB in a band of 0,5 MHz and 0,5 dB in a band of 7 MHz. If the equipment incorporates a filter, the selectivity shall be published.</p>		P
5.5.3.5	<p>Group delay variation The group delay variation in the specified frequency range shall be published.</p>		P
5.5.3.6	<p>Hum modulation For equipment incorporating an a.c. bypass the value of the hum modulation shall be published in dB at the maximum specified powering current of the equipment.</p>		P

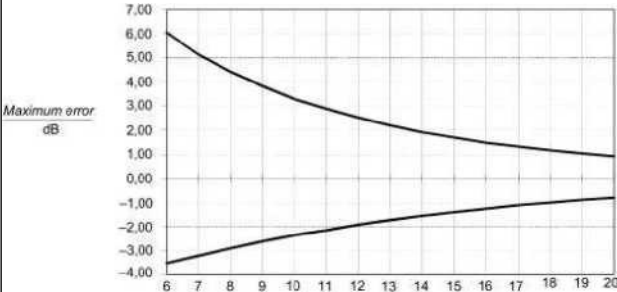
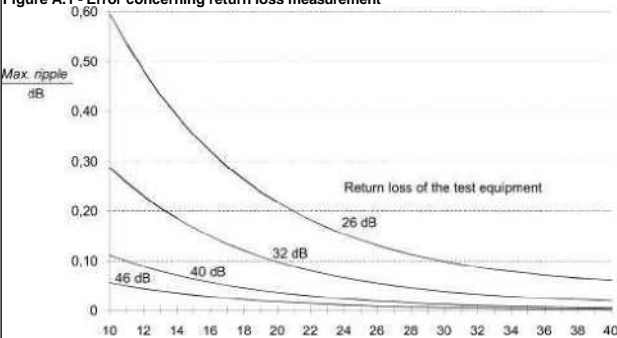
IEC-60728-4			
Cláusula	Requisito + Test	Comentarios	Resultado
	Annex A (informative)		P
	<p>Measurement errors which occur due to mismatched equipment</p> <p>The matching condition when the error introduced by the mismatch of the equipment facing the EUT and that of the equipment under test (EUT) is acceptable. Examples of maximum errors of measurement results are given in Figure A.1 and Figure A.2.</p>  <p>Figure A.1 - Error concerning return loss measurement</p>  <p>Figure A.2 – Maximum Ripple</p> <p>The return loss of test equipment should be at least 10 dB better than the expected EUT value.</p>		

IEC-60728-4			
Cláusula	Requisito + Test	Comentarios	Resultado
	Annex B (informative)		P
	<p>Differences in some countries</p> <p>8.1 Subclause 5.1.3, Finland In Finland, all equipment installed in locations that are not temperature controlled should meet their requirements within the temperature range -40 ° C to +55 ° C.</p> <p>8.2 Subclause 5.3, Table 2, Netherlands (Dutch Technical Regulations for CATV networks (Technische Voorschriften voor Centrale Antenne Inrichtingen, 3e uitgave), 21 December 1977, which are valid for CATV networks in accordance with Article 21 of the Dutch Telecommunications law (Stb. 1988, 520)). The use of looped system outlets is not allowed.</p> <p>8.3 Subclause 5.3, Table 1 and Table 2, Japan The specifications in Table 1 and 2 are under consideration for the system outlet in Japan.</p> <p>8.4 Subclause 5.4, Table 4 and Table 5, Japan The specifications in Table 4 and 5 are under consideration for splitters and taps in Japan.</p> <p>8.5 Subclause 5.5, Table 6, Japan The specifications in Table 6 are under consideration for other passive equipment in Japan.</p>		

Annex C (Lista de referencias)

	REFERENCIA	DESCRIPCIÓN
2D	519502	REPART. 5...2400MHz "F" 2D + DC
	519322	DERIV. 5...2400MHz "F" 2D 12dB +DC (out-in)
	519323	DERIV. 5...2400MHz "F" 2D 16dB +DC (out-in)
	519324	DERIV. 5...2400MHz "F" 2D 20dB +DC (out-in)
	519325	DERIV. 5...2400MHz "F" 2D 24dB +DC (out-in)
3D	519503	REPART. 5...2400MHz "F" 3D + DC
4D	519504	REPART. 5...2400MHz "F" 4D + DC
	519341	DERIV. 5..2400MHz F 4D 8dB+ DC (out-in)
	519342	DERIV. 5..2400MHz F 4D 12dB+DC (out-in)
	519343	DERIV. 5..2400MHz F 4D 16dB+DC (out-in)
	519344	DERIV. 5..2400MHz F 4D 20dB+DC (out-in)
	519345	DERIV. 5..2400MHz F 4D 24dB+DC (out-in)
5D	519505	REPART. 5...2400MHz "F" 5D + DC
6D	519506	REPART. 5..2400MHz F 6D 11/14dB + DC
	519362	DERIV. 5...2400MHz "F" 6D 12dB +DC (out-in)
	519363	DERIV. 5...2400MHz "F" 6D 16dB +DC (out-in)
	519364	DERIV. 5...2400MHz "F" 6D 20dB +DC (out-in)
	519365	DERIV. 5...2400MHz "F" 6D 24dB +DC (out-in)
8D	519508	REPARTIDOR 8D 5-2400MHz + DC
	519382	DERIV. 5...2400MHz "F" 8D 12dB +DC (out-in)
	519383	DERIV. 5...2400MHz "F" 8D 16dB +DC (out-in)
	519384	DERIV. 5...2400MHz "F" 8D 20dB +DC (out-in)
	519385	DERIV. 5...2400MHz "F" 8D 24dB +DC (out-in)
PAU	519532	PAU REPART 5...2400 "F" 2D +DC
	519533	PAU REPART 5...2400 "F" 3D +DC
	519534	PAU REPART. 5...2400MHz "F" 4D +DC
	519535	PAU REPART. 5...2400MHz "F" 5D +DC
	519536	PAU REPART. 5...2400MHz "F" 6D+DC

Annex C (Fotos Derivadores)



Referencia 519502



Referencias 519322, 519323, 519324, 519325, 519503, 519532

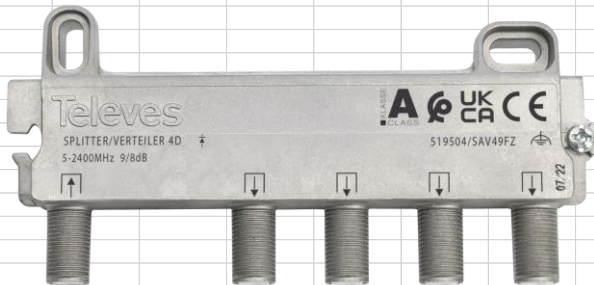

Referencias 519504, 519533

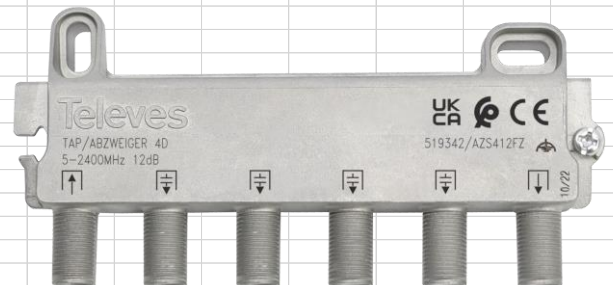

Referencias 519341, 519342, 519343, 519344, 519354, 519505, 519534

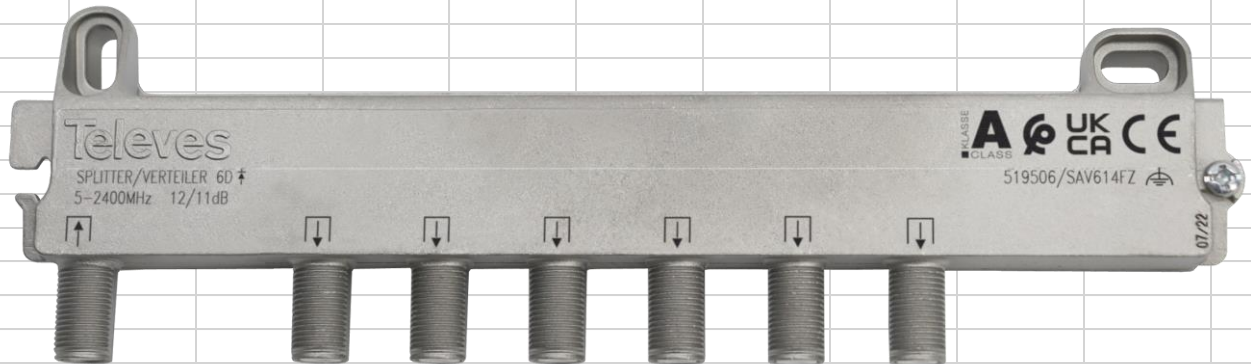

Referencia 519506, 519535

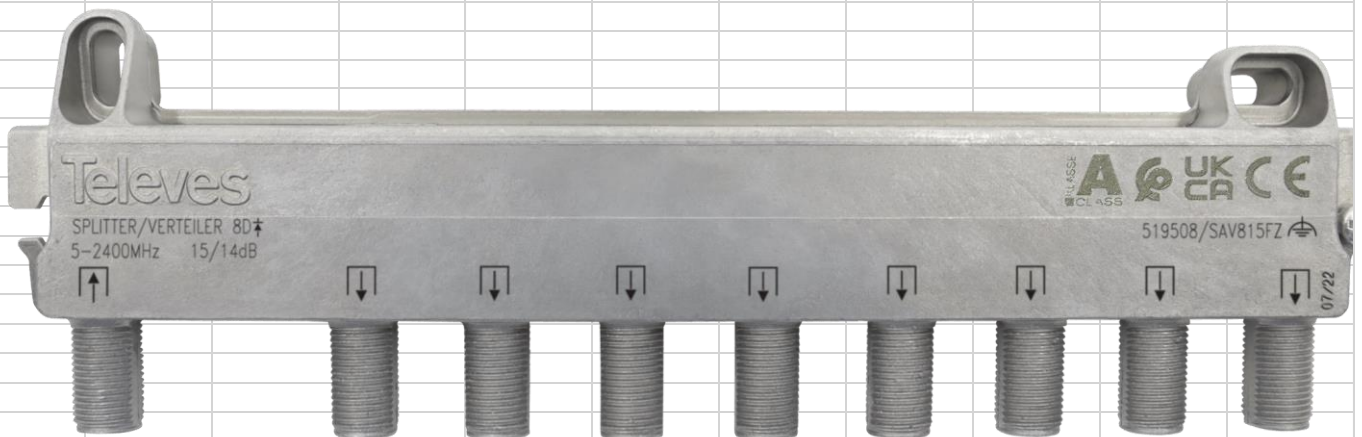

Referencia 519508

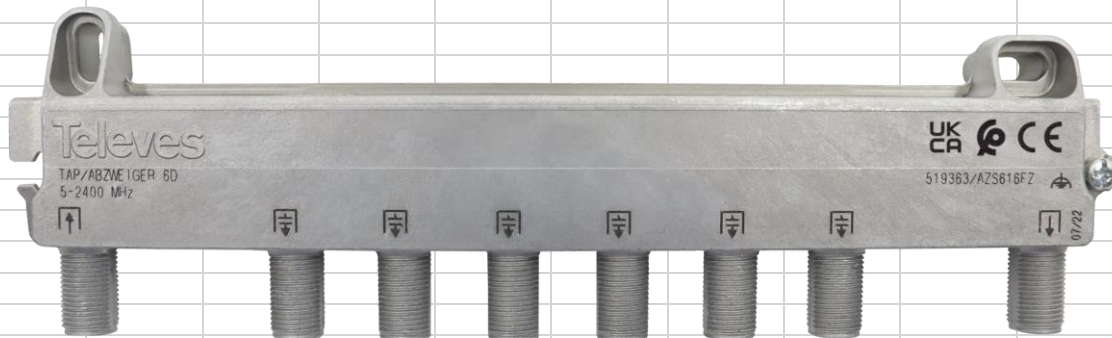

Referencias 519362, 519363, 519364, 519536

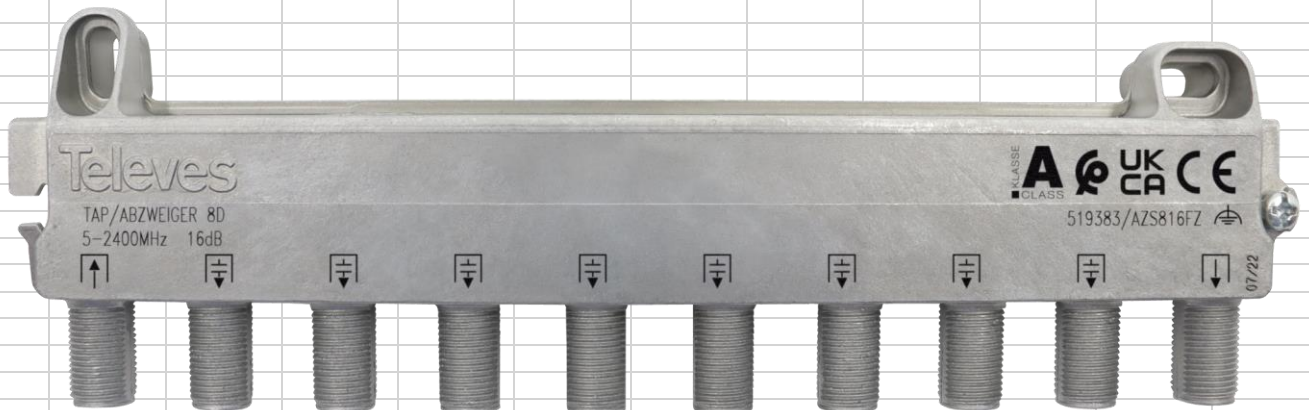

Referencias 519382, 519383, 519384, 519385