

CATALOGUE

PLL

PROFESSIONAL
LED LIGHTING

Televés[®]

[www.televés.com](#) | [www.televescorporation.com](#)



Televés Corporation[®]



Televes expresses that this document is just for information purposes and does not accept any responsibility that could be originated from possible errors or omissions regarding its content.

The product pictures included are not contractual and Televes could supply products as shown or these could suffer variations, modifications and/or alterations at any time and without notice.

INDEX



4 INTRODUCTION
PROFESSIONAL LED LIGHTING



10 **ATMOSLED** ★
OUTDOOR LED LIGHTING



22 **INNERLED**
INDOOR LED LIGHTING



28 **LAMPS**
NEW ORNAMENTAL LUMINAIRES



34 **RETROFIT**
SWITCHING TO LED LIGHTING



40 **LED FLOODLIGHTS** ★
OUTDOOR AND INDOOR LED LIGHTING



48 **PATHLED**
BEACONS

Taking advantage of its wide experience in electronic technology and metal structure manufacturing, Televés offers a complete set of outdoor and indoor solutions in the Televés LED lighting range. Televés' luminaires allow for energy savings of up to 80% as compared to conventional lighting systems. They stand out for their first-class engineering and their excellent thermal management that ensure a long maintenance-free working life.

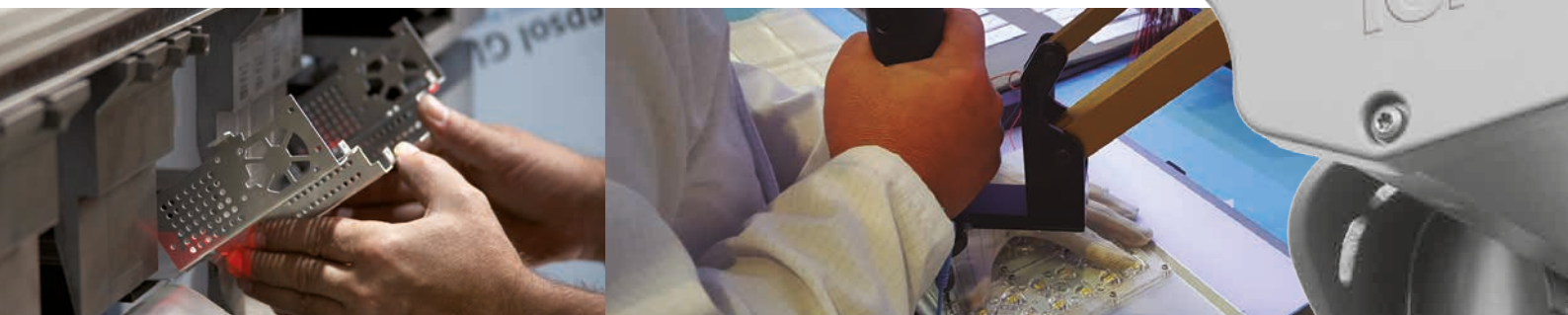

Televés' LED lighting solution provides from a PROGRAMMING AND CONTROL option to the point to point CONNECTIVITY.

This enables the implementation of projects in which the installation's light intensity has to be programmed based on schedules defined by a manager.

QUALITY GUARANTEED

Our commitment to quality is one of our core values and ensures all our products meet our clients' most stringent requirements.

We develop the product all the way from design to manufacturing. This is why we are in a position to provide a high degree of versatility and personalisation in the design, and supply products that are fully adapted to meet each client's specific needs.

In the Televés Corporation's post-production laboratory, we carry out rigorous electromagnetic compatibility and electrical safety tests, as well as excessive heat exposure and freezing temperatures tests. We also perform extreme component ageing tests to validate the product correct performance under extreme environmental conditions.

As a result, our luminaires exceed the expectations of a market that requires high-efficiency and high-quality products to meet all the established requirements.

*Spanish technology,
designed and manufactured
in Spain.*

LED technology is definitely the lighting technology of the future, given the **huge benefits** it provides as compared to traditional lighting.



ADVANTAGES



- Up to 80% energy savings as compared to traditional lighting.
- Low power consumption.
- Low maintenance.
- Long service life.
- High energy efficiency.



- High light quality.
- Instant start.
- The on/off cycles do not reduce product's service life.
- Low heat emission.
- Vibration resistant.
- Adjustable intensity thanks to the lighting control.



- Low voltage.
- Free of electromagnetic interference.
- No infrared or UV.



- Low CO₂ emissions.
- Mercury-free.
- Recyclable.
- Do not create light pollution.
- No maintenance costs.



ENERGY SAVINGS

The **energy savings** achieved by using our luminaires can be **very significant**, depending on the luminaire being replaced and the specific type of lighting required.

Our luminaires have a **long maintenance-free working life**, which increases the cost savings as compared with other technologies.

An assessment must be always carried out prior to replacing conventional luminaires by equivalent ones as per the site lighting requirements.



CERTIFICATIN



ENEC (*European Norms Electrical Certification*). A certification recognized both nationally and internationally, granted in Spain to manufacturers only by AENOR, in the role of entity for product conformity assessment. With this certification, AENOR certifies:

- The product was evaluated in an independent, impartial laboratory according to the applicable standards.
- A 100% of the products passed a specific electric test in compliance with the electrical safety regulations.
- The manufacturer passed the audit on manufacturing requirements, quality controls and production facilities.
- The manufacturer is ISO 9001 and ISO 14001 certified.
- Annual production revision to assess conformity with the requirements.



ISO 9001:2015: Quality management system.

ISO 14001:2015: Environmental management system.

GUARANTEE SCHEME

The luminaires in the Televes range stand out for the first-class engineering and the excellent thermal management.

This is why Televes provides a 5 or 7 year luminaire guarantee (depending on the model) with the possibility of further extension.



DRIVERS

- **Drivers designed and manufactured by Televés in Spain.**
New models certificated by AENOR.
- **Class II electric insulation** to secure any contact with active parts. No grounding connection required.
- **SELV:** Output voltage under 60 V. Does not require any additional safety measures to avoid electric shock hazard.
- Equipped with a **separate output for each LED module.**
- 196 - 254 VAC Input voltage.
- Up to 700 mA constant output current.
- **Short-circuit, open circuit, surge and overheating protection:** equipped with a protection system that turns the luminaire off in case a given critical temperature is reached.
- **Equipped with up to 10 KV electric discharge protection.**
- PFC > 0.95.
- Mounted using an **easily removable** support for a convenient replacement.
- New options for 40W.

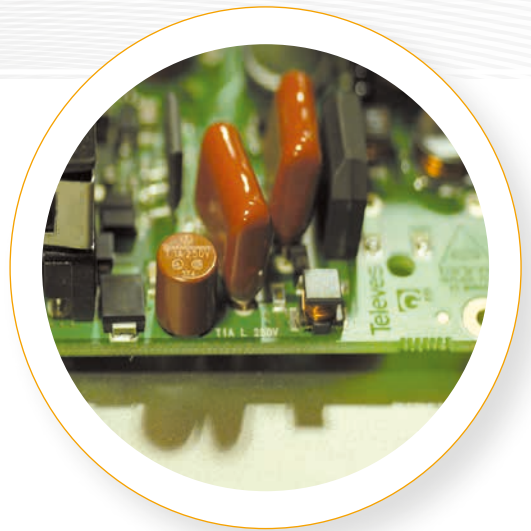

IP67

*Our drivers and LED modules
are designed and manufactured in
Televés.*

100% European Quality

LED MODULE

- 12 LEDs modules **designed and manufactured by Televés in Spain.**
- The aluminium-based circuit contributes to heat dissipation.
- Equipped with a quick connector for an **easy mount and replacement.**
- Up to 190 lumen/W module efficiency.
- Protected against electrostatic discharge.
- **Wide range of Colour Temperature**
From ultra warm white to cool white
 - 2,700, 3,000, 4,000 or 5,000K.
 - ★ **2,200K** (Ultra warm white IAC).
- The independent connections **increase their working life.**
- **The optical system is IP67 certified** against water and dust.
- **Minimum CRI: 70.** On demand CRI>80.



NORMATIVA

- *Drivers designed and manufactured by Televés in Spain.*
- *LED module designed and manufactured by Televés in Spain.*



TESTS PERFORMED IN A LABORATORY
CERTIFIED BY A ACCREDITED ENTITY
IN EUROPE



LENSES

- Now more options to reach the optimal solution in all scenarios.
- Our luminaires are equipped with european **high-quality** lenses.
- The optical design allows **lighting just on the required spot**.
- The type of lenses used allow to increase the separation between luminaires, thus raising performance and reducing costs.
- They limit LEDs' direct vision, **which enhances convenience in the field of vision**.
- Multiple combinations are available depending on the application, the road width and the mounting height.



For other lens types, please check with us.

LIGHT DISTRIBUTIONS: FLOODLIGHT

Approximate reference illumination diagrams

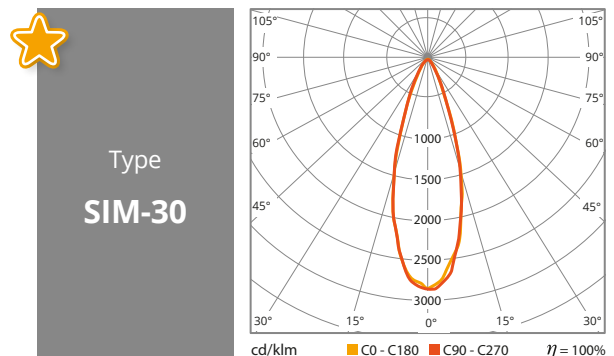
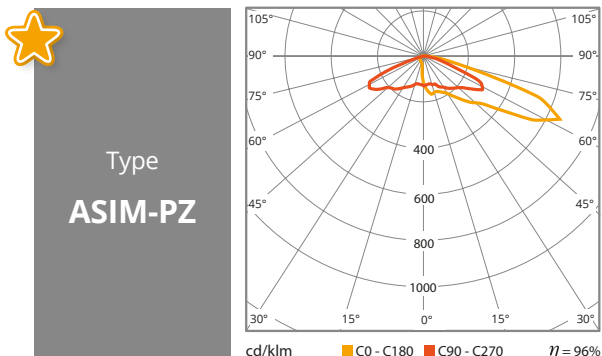
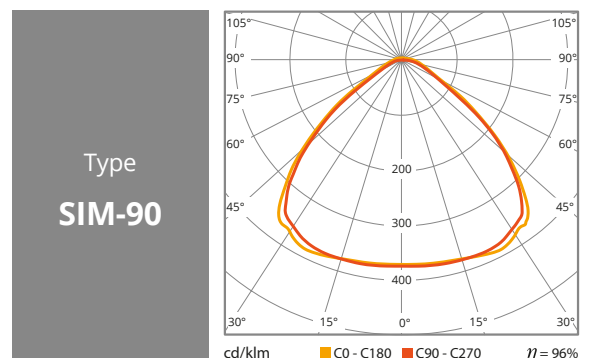
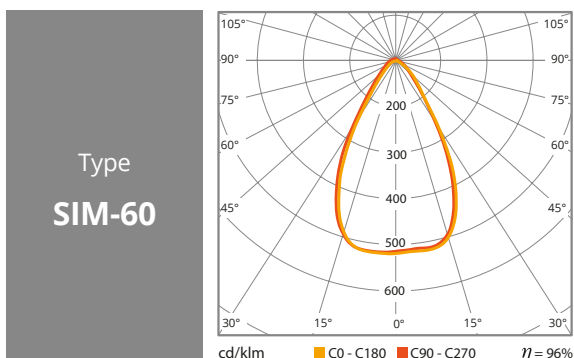



LIGHT DISTRIBUTIONS: ROAD

Approximate reference illumination diagrams

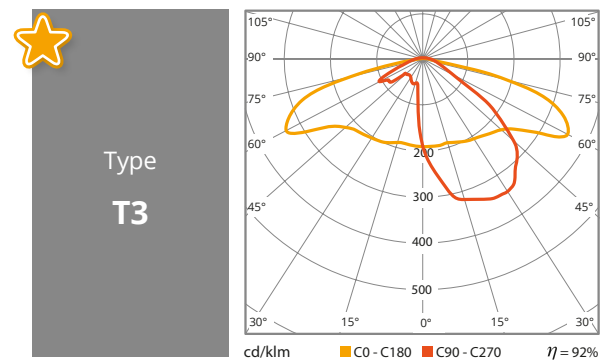
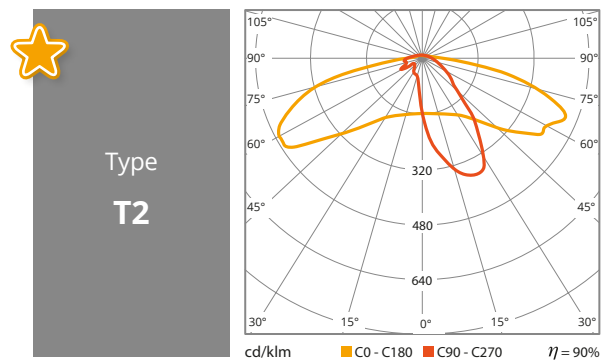
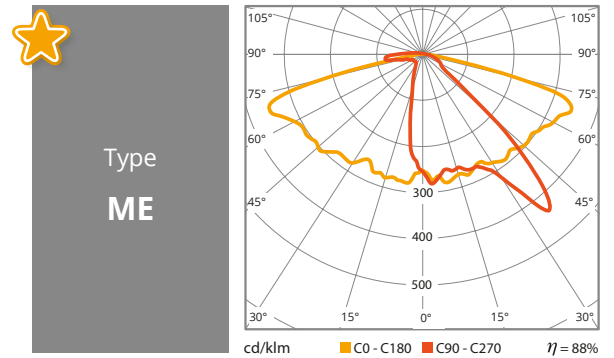
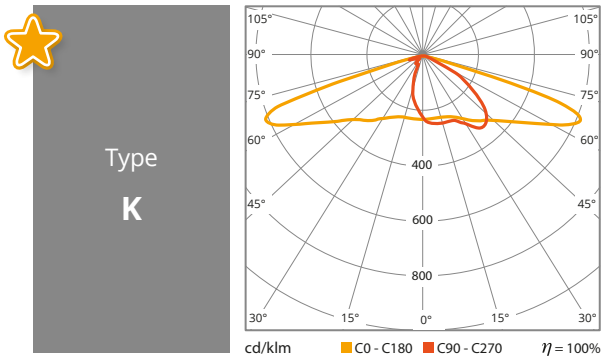
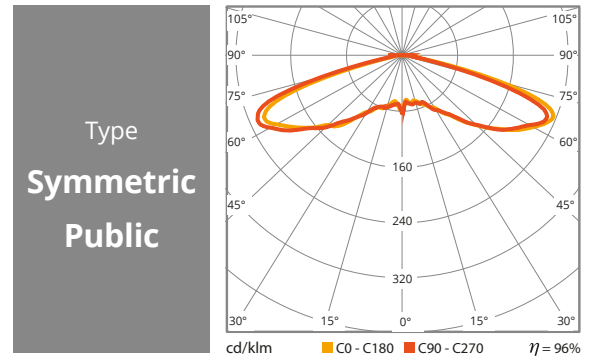
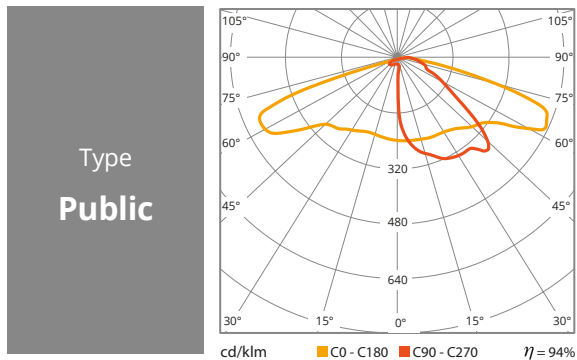

ATMOSLED

OUTDOOR LED LIGHTING



QUALITY AND EFFICIENT

Our highly versatile luminaires adapt to any environment.
They are easy to mount and maintain.

ADVANTAGES MAKE THE DIFFERENCE



NEW DRIVERS

Designed and manufactured in Televés.

■ WIDE RANGE OF COLOUR TEMPERATURES

From ultra warm white to cool white

■ 3,000, 4,000 or 5,000K

★ **2,200K** (Ultra warm white)

■ CLASS II

No need for grounding connection.

■ SELV

Output voltage under 60V.

■ INDIVIDUAL OUTPUTS FOR EACH LED CIRCUIT

They ensure the same current flows across all LEDs at all times.

■ DIMMING OR LIGHTING LEVEL CONTROL

Optimizes energy savings.

■ WIDE RANGE OF OPERATING TEMPERATURES

From -20° to 50 °C *.



NEW CIRCUIT AND LED MODULE

More efficient.

■ IK10

Tamper proof.

■ MULTIPLE MOUNTING OPTIONS

Can be adapted to multiple anchoring systems and positions.

■ CORROSION RESISTANT

Made of anodised aluminium with IP67 protection degree.

■ LIGHT POLLUTION PREVENTION

No light is emitted to the upper hemisphere.

■ VERSATILE FINISH

Multiple anodized or painted finishes in any colour in the RAL range.

■ L80 B10

Estimated luminaire life > 100,000 hours for a working environment temperature of 25°C.

■ UP TO 10 KV ELECTRIC DISCHARGE PROTECTION.

* The maximum range depends on the specific model.

MULTIPLE APPLICATIONS

■ STREET (ROAD) LIGHTING:

Streets, avenues, squares, parks, residential areas, industrial areas, roads, highways...

■ MULTIPLE OUTDOOR AREAS:

Outdoors of industrial premises, shopping centres, recreational areas, sports facilities...

■ FLOODLIGHT:

Historic monuments, building fronts, commercial premises...

CHARACTERISTICS

STRUCTURE

- **Extruded anodized aluminium** housing, specifically designed for a **perfect thermal management** keeping both LED and driver's temperature as low as possible.
- Two independent areas: a **eaLED cavity (IP67)** where both equipment and electrical connections are housed, and a **ventilated cavity** that functions as a heat sink.
- **Manufactured in Televes.** From the LED circuit and the driver to the luminaire blend.

THERMAL MANAGEMENT

Heat conduction and convection in the luminaire is favoured by dissipation curves included in the profile itself and located inside a ventilated cavity, separated from the electric area.

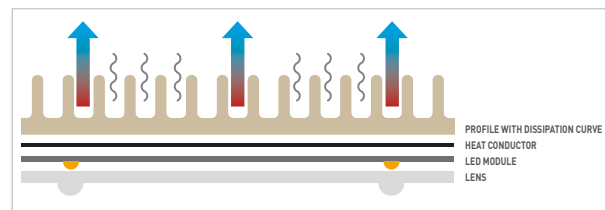

OUTSTANDING CORROSION RESISTANCE

- The structure's anodized finish improves both hardness and corrosion resistance.

COLOURS

- **MATT STEEL** lacquered (RAL 9006 aluminium).
- Available in any RAL colour on demand.



MATT STEEL
(aluminium)

SCREWS

- All screws are corrosion resistant **stainless steel**.

SIDE COVERS

- Made of injection-moulded lacquered aluminium.
- They have **vents to allow the air to flow** in the ventilated cavity.

TIGHTNESS

- **The optical system is IP67 certified** for water and dust tightness.



PRESSURE COMPENSATION DEVICE

The **ATMOSLED** luminaires are equipped with a pressure compensation device to prevent dust and humidity to be absorbed whenever the inside pressure is lower than the outside pressure.

CONNECTIONS

- **ATMOSLED** luminaire connections provide permanent tightness and electrical safety.
- The M16 stuffing gland ensures IP67 is met in the equipment's tight cavity.
- External IP68 connector for 6 to 12 mm diameters (Ø 6 -12 mm)

ATMOSLED OUTDOOR LED LIGHTING

★ **ATMOSLED E and N Series**

- The **E SERIES** stands out for efficiency and performance, up to **160 lum/W**.
- The **N SERIE**. Televés has developed the new range aiming at **maximum efficiency and robustness**. The N series is equipped with an **ANSI C136.41 NEMA** regulation connector, which allows establishing a plug-and-play connection with the remote control nodes, therefore providing connection capacity to IoT infrastructures.



▶ **ATMOSLED N Series**

LIGHT DISTRIBUTIONS

Approximate reference illumination diagrams

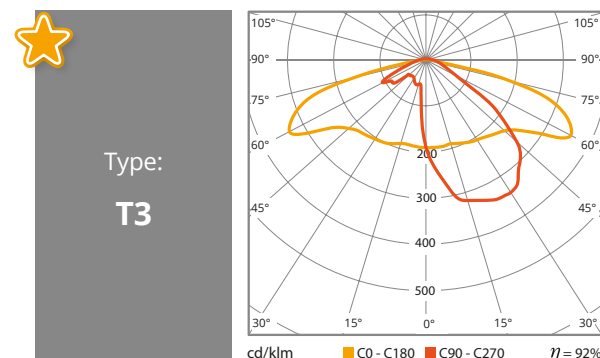
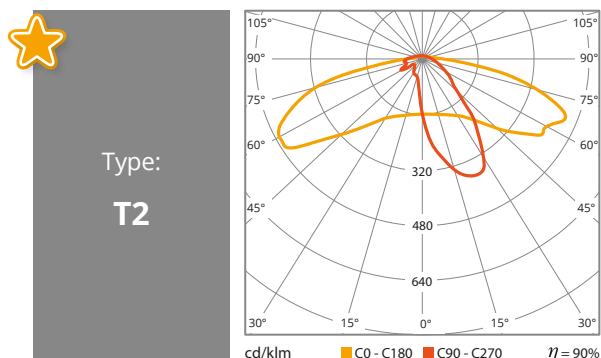
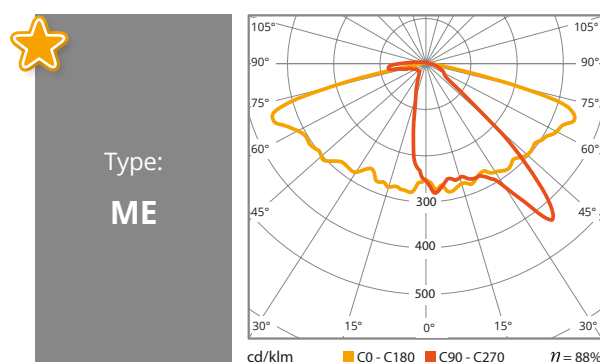
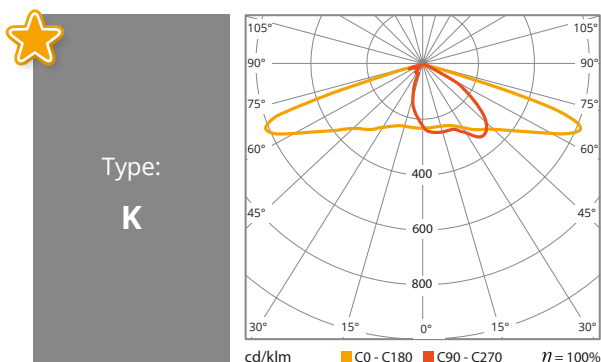
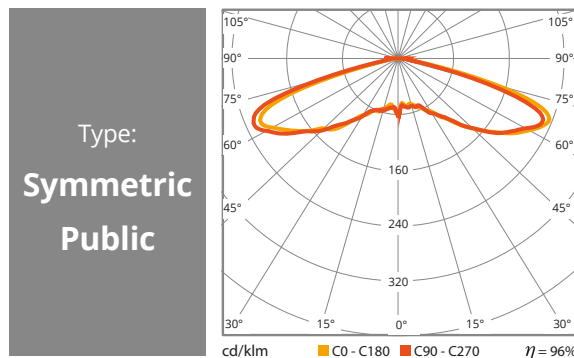
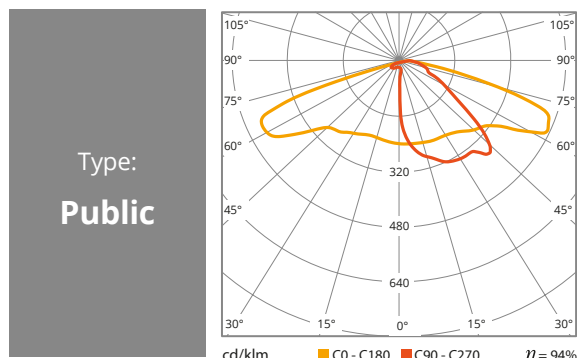



CRI = 70* - CTT 2,200 / 2,700 / 3,000 / 4,000 / 5,000K - FHS<0,1% - PF>0,95



REFERENCES ⁽¹⁾	No. LEDs	WEIGHT	L	OPERATING CURRENT	TOTAL POWER CONSUMPTION [±8%]	TOTAL LUMINOUS FLUX (4.000K)	WORKING LIFE ⁽²⁾
		(kg)	(mm)	(mA)	(W)	(lm)	(h)
680500xxxxxxx	12	5.9	260	400	29	4,350	>100,000
				500	39	5,538	
681500xxxxxxx	24	7	340	330	49	7,746	>100,000
				370	59	8,968	
682500xxxxxxx	36	7.2	340	310	69	10,626	>100,000
				330	78	11,622	
683500xxxxxxx	48	9.4	388	300	86	14,040	>100,000
				340	108	15,984	

CRI = 70* - CTT 2,200 / 2,700 / 3,000 / 4,000 / 5,000K - FHS<0,1% - PF>0,95



REFERENCES ⁽¹⁾	No. LEDs	WEIGHT	L	OPERATING CURRENT	TOTAL POWER CONSUMPTION [±8%]	TOTAL LUMINOUS FLUX (4.000K)	WORKING LIFE ⁽²⁾
		(kg)z	(mm)	(mA)	(W)	(lm)	(h)
680300xxxxxxx	12	5.9	260	400	29	4,350	>100,000
				500	39	5,538	
681300xxxxxxx	24	7	340	330	49	7,746	>100,000
				370	59	8,968	
682300xxxxxxx	36	7.2	340	310	69	10,626	>100,000
				330	78	11,622	
683300xxxxxxx	48	9.4	388	300	86	14,040	>100,000
				340	108	15,984	

- Working environment temperature should be in the -15 °C to 45 °C range.

* On demand: CRI > 80.

(1) Reference breakdown example: page 50.

(2) L80 B10 A 25°C for a working environment temperature of 25°C.

Estimated working life of the luminaire:

L: Luminous flux maintenance.

B: Probability of luminous flux loss.

LxBy for a given number of hours and a given ambient temperature, usually 25°C.

Indicates the time when the flux level of y% of the LED population used for a given type of luminaire is likely to be below x%.



ATMOSLED 5 and 7 Series

- **SERIES 5** stands out for longevity and performance, and is guaranteed for 7 years.
- **SERIES 7** has a higher working power, and provides a higher light intensity for the same amount of LEDs (guaranteed for 5 years).



LIGHT DISTRIBUTIONS

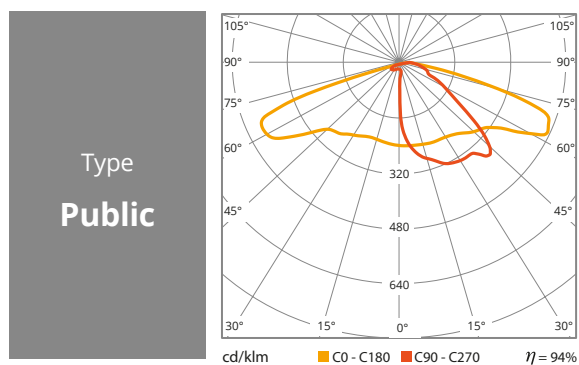

Approximate reference illumination diagrams

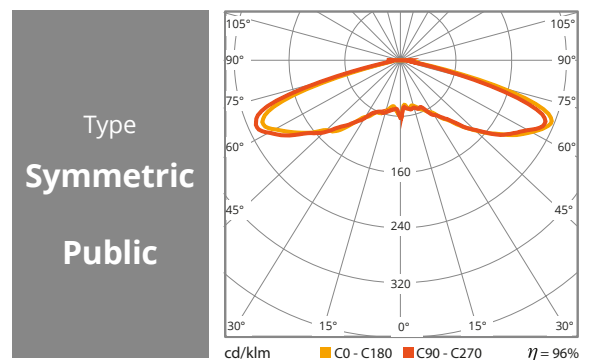



CRI = 70* - CCT=2,200 / 2,700 / 3,000 / 4,000 / 5,000K - FHS<0,1% - PF>0,95

5
SERIES

REFERENCES ⁽¹⁾	No. LEDs	WEIGHT	L	OPERATING CURRENT	TOTAL POWER CONSUMPTION [±8%]	TOTAL LUMINOUS FLUX (4.000K)	WORKING LIFE ⁽²⁾
		(kg)	(mm)	(mA)	(W)	(lm)	(h)
601500xxxxxxx	24 ⁽³⁾	7	340	500	39	4,800	>100,000
602500xxxxxxx	36 ⁽³⁾	7.2	340	500	60	7,200	>100,000
603500xxxxxxx	48 ⁽³⁾	9.4	440	500	80	9,607	>100,000
604500xxxxxxx	60	9.6	520	500	95	11,335	>100,000
605500xxxxxxx	72	9.8	520	500	120	14,300	>100,000

CRI = 70* - CTT 2.200 / 2.700 / 3.000 / 4.000 / 5.000K - FHS<0,1% - PF>0,95

7
SERIES

REFERENCES ⁽¹⁾	No. LEDs	WEIGHT	L	OPERATING CURRENT	TOTAL POWER CONSUMPTION [±8%]	TOTAL LUMINOUS FLUX (4.000K)	WORKING LIFE ⁽²⁾
		(kg)	(mm)	(mA)	(W)	(lm)	(h)
610500xxxxxxx	12	5.9	260	720	29	3,280	>100,000
				650	26	3,042	
611500xxxxxxx	24	7	340	720	58	6,313	>100,000
612500xxxxxxx	36	7.2	340	720	85	8,965	>100,000
613500xxxxxxx	48	9.4	440	630	100	1,1016	>100,000

- Working environment temperature should be in the -15 °C to 45 °C range. Estimated working life of the luminaire:
 * On demand: CRI > 80. L: Luminous flux maintenance.
 (1) Reference breakdown example: page 50. B: Probability of luminous flux loss.
 (2) L80 B10 A 25°C for a working environment temperature of 25°C. Indicates the time when the flux level of y% of the LED population used for a given type of luminaire is likely to be below x% .
 (3) -15 to 50°C for Atmosled5 of 24, 36 and 48 LEDs

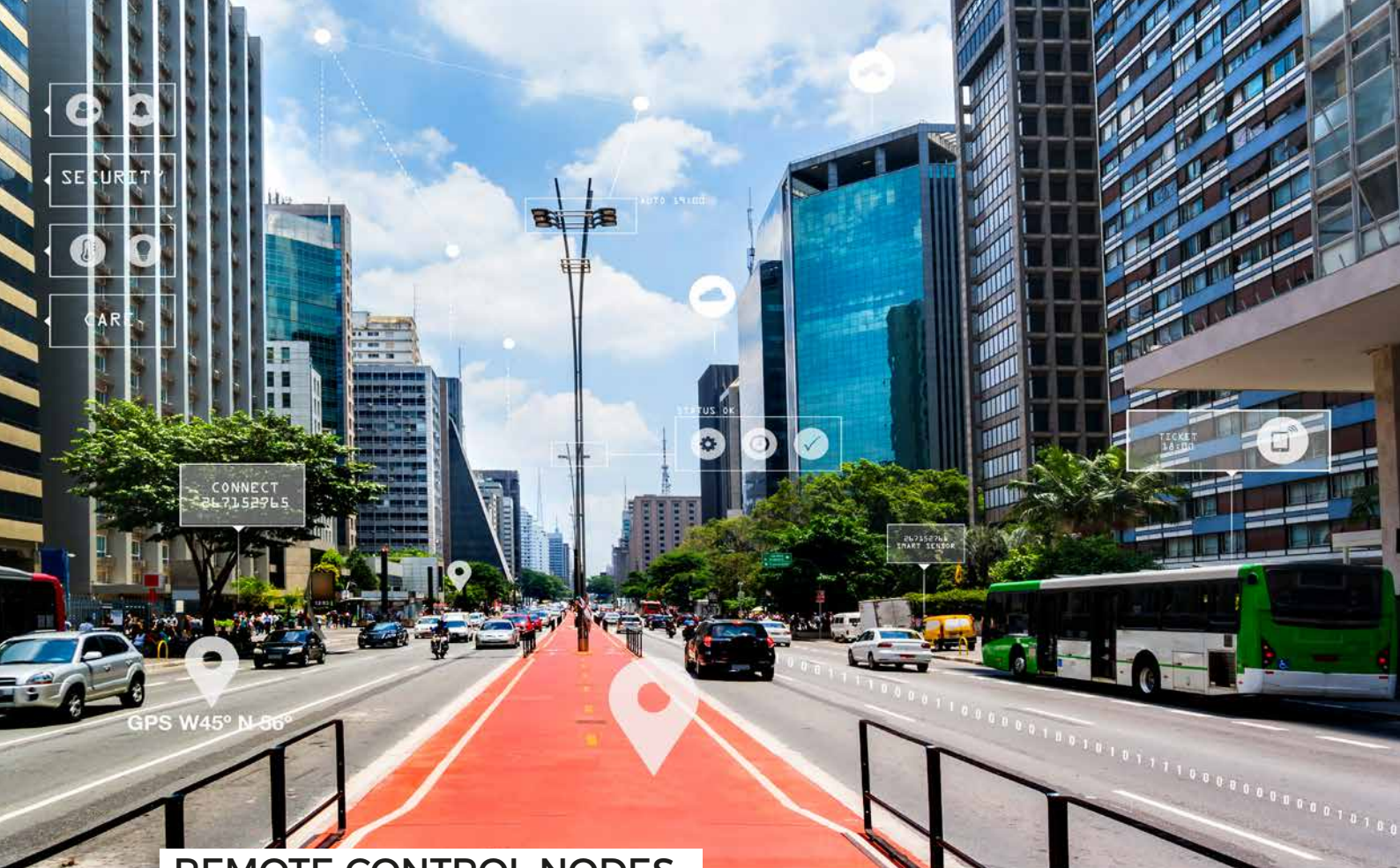

REMOTE CONTROL NODES

Point-to-point connectivity of LED lighting systems has become a must in Smart City management due to the extension, complexity, and undeniable benefits it brings to the citizens.

The main advantages are:

- **System efficiency** increase, as sensorization allows the modification of intensity based on the population needs in each location, in a much more flexible way than pre-set timing schedules.
- Capacity to **control**, and therefore to adapt to instant lighting changes required in the city (level increase due to unscheduled causes such as events, patron saints' feasts, or emergency situations).
- Capacity to **monitor the network**, and therefore to early detect incidents, which opens the door to planning and efficiency in network operation and maintenance.

PLC: Traditional electric power line transmission technology for communication signal transmission purposes. PLC takes advantage of the electricity grid to convert it into a high-speed digital line for data transmission.

3G: The third generation of mobile telephony voice and data transmission using UMTS (*Universal Mobile Telecommunications System*).

Televés has equipped the new luminaire series with **ATMOSLED N** the **ANSI C136.41 NEMA**, regulation connector that allows establishing a plug-and-play connection with the remote control nodes, therefore providing connection capacity to IoT infrastructures.

This **open interface** allows our **ATMOSLED N** series to connect to any remote control system, irrespective of the technology used in each Smart City project, based both on the terrain and on the presence or not of other IoT networks in the city, or in the use cases and control to be implemented, which may be based on an electric line connection (PLC, wideband PLC) or on wireless networks (3G, NB-IoT, LoraWan, LoraMesh, Zigbee...).

NB-IoT: (NarrowBand IoT). First open, standard communication technology to connect the small objects of our everyday life to the Internet. This technology uses the mobile network (3G/4G/5G) to connect any object of our everyday life in an easy, safe and reliable way. Since it uses the communications network of a mobile operator, it provides better coverage levels both indoors and outdoors.

LoRa: Wireless technology that uses one type of radio frequency modulation.

DIMMING OR AUTONOMOUS LIGHTING CONTROL

El *dimming* or lighting control allows the regulation of each light point to the level supported by the lamp; in this case, 10 light levels.

This **STANDALONE SOLUTION** consists in a controller installed on each luminaire with a pre-programmed timing for each lamppost that specifies the light level required for each hour of the night.

This system increases components' operating life, thus reducing maintenance costs and helping to increase the energy savings associated with LED lighting.

By default, the dimming's lighting plan consists in two time slots with maximum lighting and an intermediate slot with lower lighting. The system adjusts to the on/off schedule specified on the control panel, so that maximum lighting level (100%) is provided during the busy hours (early in the morning and late at night), and is progressively reduced during quieter times (dawn), reaching a lighting level of 70%. Furthermore, dimming is readjusted to adapt to schedule changes according to the time of year.

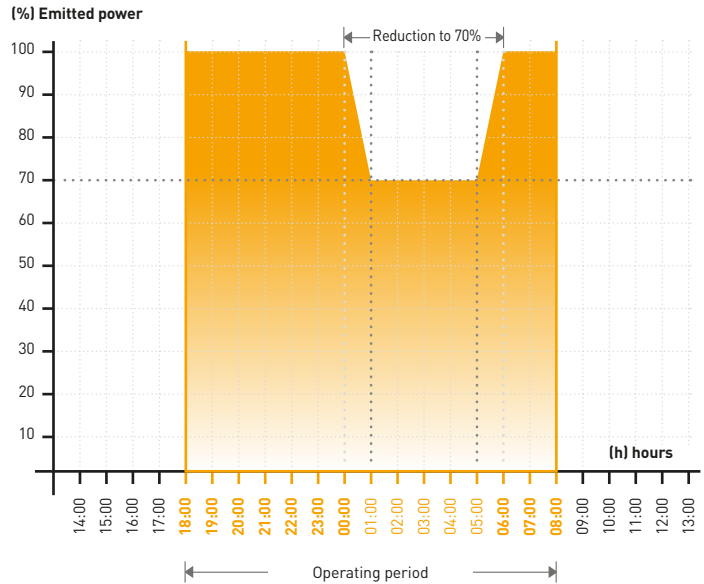

Other programming options are available on demand (check with us).
Dimming is only available for the references specified in the annex.

ATMOSLED 5, 7 and E Series

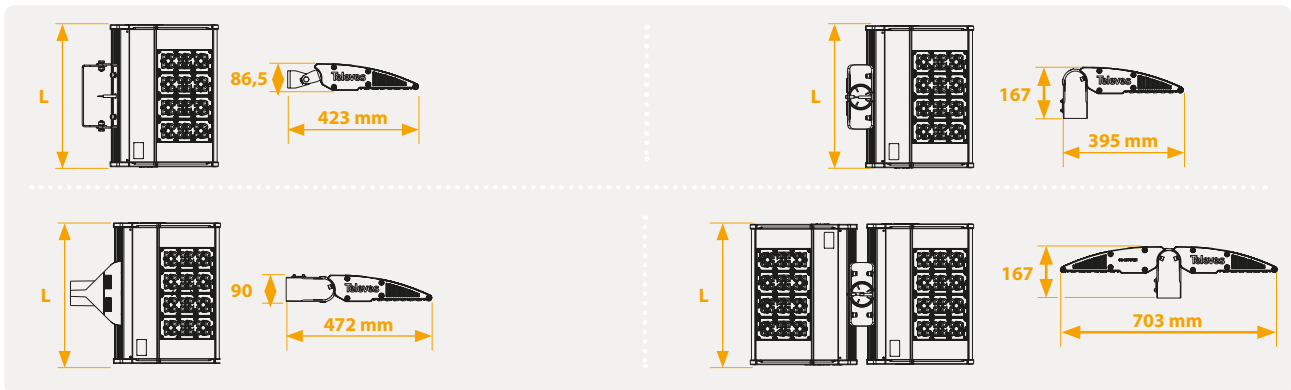

ATMOSLED N Series

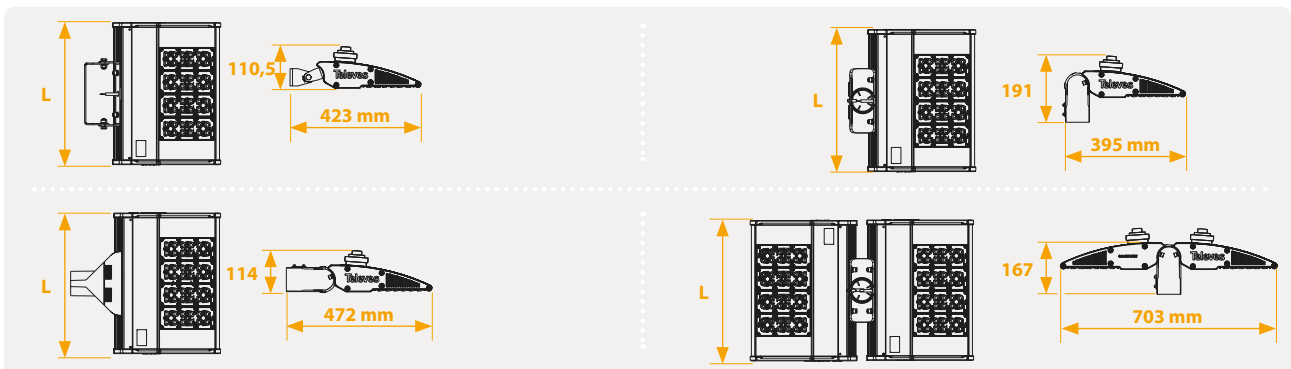

ATMOSLED OUTDOOR LED LIGHTING

LOCATION

MOUNTING HEIGHTS

The charts below show the approximate heights that are appropriate for each of the series types.

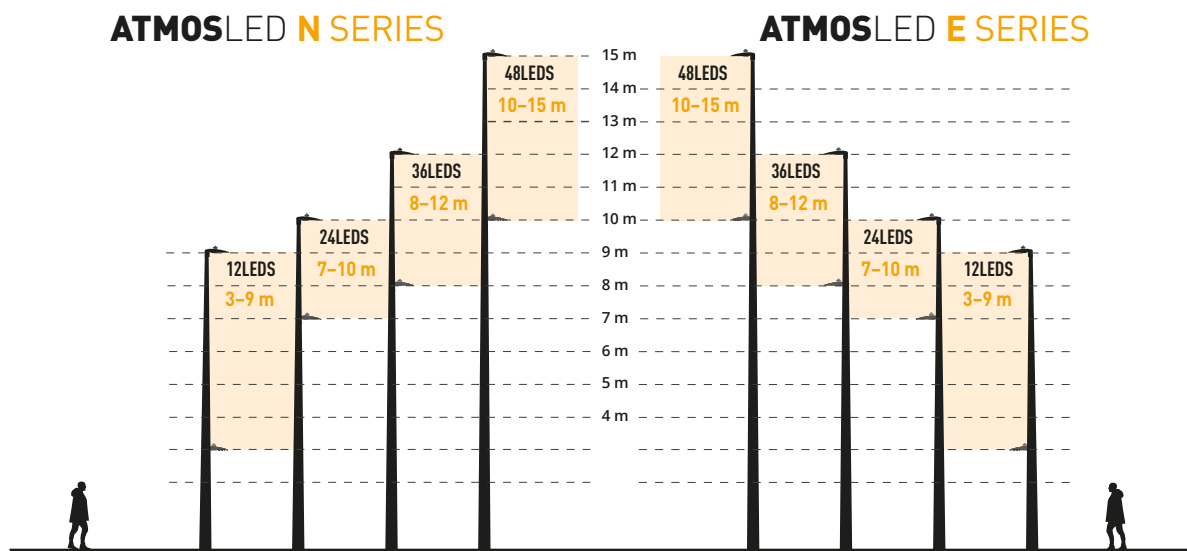
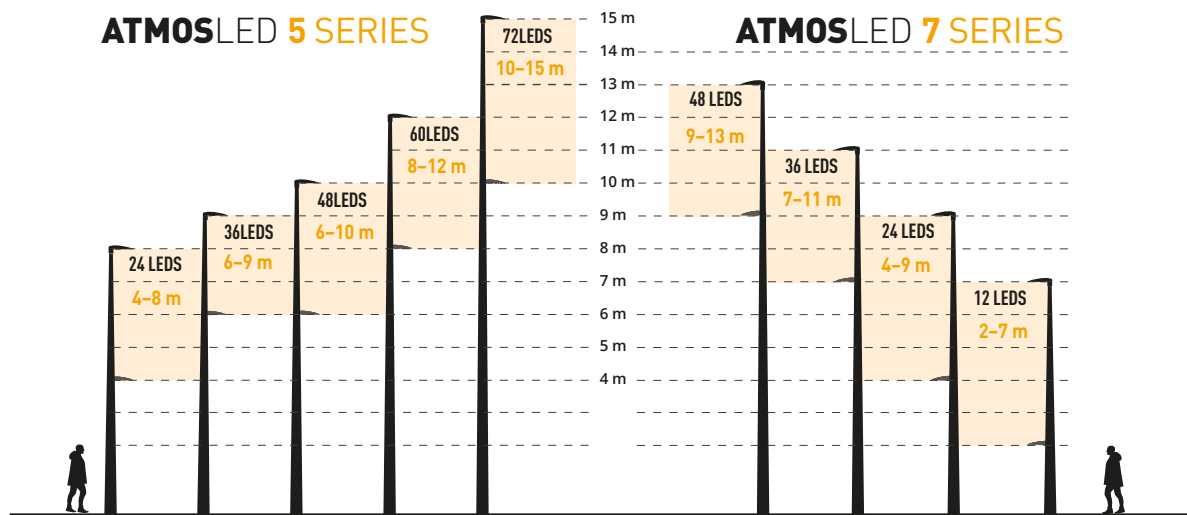

REGULATION

EN 60598-1:2015 + A1:2018
 EN 60598-2-3:2003 + A1:2011
 EN 62471:2008
 EN 62031:2008 + A1:2013 + A2:2015
 EN 62493:2015

EN 55015:2013 + A1:2015
 EN 61547:2009
 EN 61000-3-2:2014
 EN 61000-3-3:2013

TESTS PERFORMED IN A
 LABORATORY CERTIFIED
 BY A ACCREDITED
 ENTITY IN EUROPE



MOUNTING

Our luminaires can be mounted in different positions which allows them to adapt to any environment conditions.



ACCESSORIES

ARM

- Made of **injection aluminium** and lacquered in RAL 9006 aluminium colour.
Available in other RAL range colours on demand.
- **Adaptable** for mounting on commercial columns with diameters ranging from 40 to 60 mm (Ø: 40 - 60 mm).
Adapters are available for other tube diameters.
- Allows a luminaire **rotation up to 30°**.



- ▲ 69000201 (Horizontal support)
- ▲ 69000401 (Vertical support)
- ▲ 69000601 (Double support)

Rotation adjustable in 5-degree steps

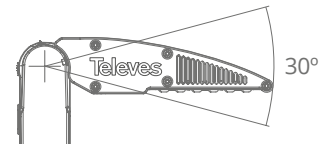
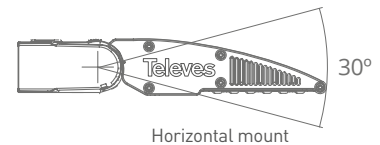

WALL MOUNT SUPPORT

- Support designed for luminaire anchoring.
- Made of corrosion-resistant **galvanized and lacquered steel**.
Available in any of the RAL range colours on demand.
- Allows a luminaire **rotation up to 60°**.



SPD MODULE

- Complementary accessory that provides **additional surge protection** in case of thunderstorms.
- Two models are available: **10,000 or 20,000 A** maximum current.
- **Compliant with UL1449 and IEC61643-11 standards** for Class II.
- They allow for **maintenance costs reduction** and ensure **an even longer product service life**.
- **10 KV surge protection**.

INNERLED

INDOOR LED LIGHTING



QUALITY AND EFFICIENCY

ADVANTAGES MAKE THE DIFFERENCE

- **UNPARALLELED SAVINGS**
Up to 80% energy savings.
- **WIDE RANGE OF COLOUR TEMPERATURES**
From warm white to cool white
 - 4.000 or 5.000K
- **MINIMIZES MAINTENANCE COSTS**
Long working life.
- **WIDE RANGE OF OPERATING TEMPERATURES**
From -30° to 40 °C.
- **MULTIPLE MOUNTING OPTIONS**
Can be adapted to multiple anchoring systems and positions. Available accessories.
- **CAN BE CUSTOM RECESSED**
- **QUICK RETURN ON INVESTMENT**
- **VERSATILE FINISH**
Multiple anodized or painted finishes in any colour in the RAL range.
- **LONG WORKING LIFE**
L80 B10 ≥ 70,000 hours.
- **EASY CONNECTION**
No need open the luminaire for its installation.
- **IMPROVED EFFICIENCY**

MULTIPLE APPLICATIONS

Factories, industrial premises, warehouses,
shops , fairs, high work areas,
logistics platforms, sports centres...

INNERLED INDOOR LED LIGHTING

CHARACTERISTICS

STRUCTURE

Anodized aluminium specifically designed for a perfect thermal management that keeps both LED and driver's temperature as low as possible.

MAINTENANCE

- Easy component replacement.
- Information included in the product's manual.



EFFICIENCY

Final efficiency up to 150 lumen/W, including drivers' losses.

THERMAL MANAGEMENT

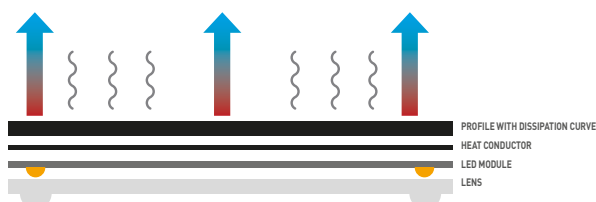

MOUNTING

Direct mains connection.
Easy replacement of existing light points.

Furthermore, the luminaire can be installed in two ways:

- Suspended from the ceiling.
- Recessed in the ceiling or wall (support)

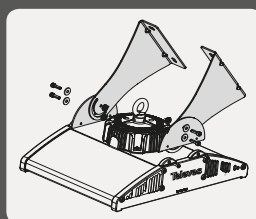

(INNERLED support not included)

COLOURS

Lacquered in RAL 9006 grey or RAL 9005 black.

Available on demand in any colour in the RAL range.



INNERLED SERIES

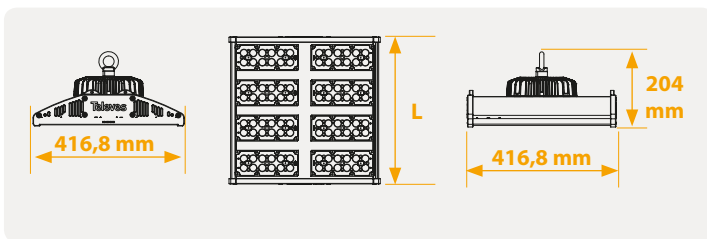

CRI = 70 (On demand CRI>80) - CTT 4.000 / 5.000K - FHS < 0,1% - PF > 0,95

INNERLED	REFERENCES ⁽¹⁾	No. LEDs	WEIGHT	L	OPERATING CURRENT	TOTAL POWER CONSUMPTION [±8%]	TOTAL LUMINOUS FLUX (4.000K)	WORKING LIFE ⁽²⁾
			(kg)	(mm)	(mA)	(W)	(lm)	(h)
	623500xxxxxxx	48	5.1	214	400	80	12,000	100,000
	625500xxxxxxx	72	6.8	311	400	130	19,500	100,000
	627500xxxxxxx	96	9.0	405	400	200	30,000	100,000

(1) Reference breakdown example: page 50.

(2) L80 B10 A 25°C for a working environment temperature of 25°C.

LOCATION

EN 60598-1:2015 + A1:2018
EN 60598-2-5:2015
EN 62471:2008
EN 62031:2008 + A1:2013 + A2:2015
EN 62493:2015
EN 55015:2013 + A1:2015
EN 61547:2009
EN 61000-3-2:2014
EN 61000-3-3:2013

TESTS PERFORMED IN A
LABORATORY CERTIFIED
BY A ACCREDITED
ENTITY IN EUROPE



DIMMING OR LIGHTING CONTROL



Dimmable 1-10V and DALI models available, fully compatible with solutions of presence detection and which allows adjusting the light level to the installation needs according to the natural light and the presence.

INNERLED INDOOR LED LIGHTING



LOCATION

MOUNTING HEIGHTS

Specific parameters are established for an appropriate location based on the power of each model.

The charts below show the approximate heights that are appropriate based on the number of LEDs. However, each scenario is different, and a prior check is recommended in order to confirm the height.

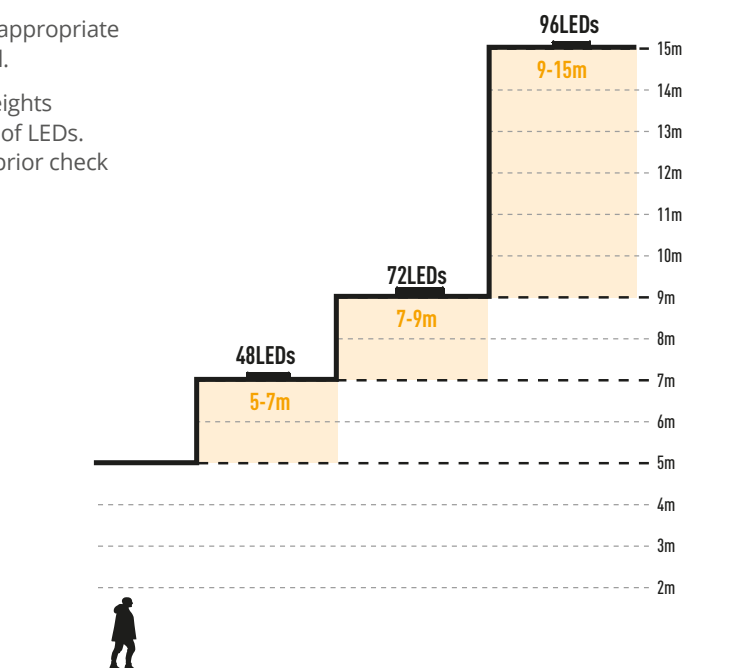

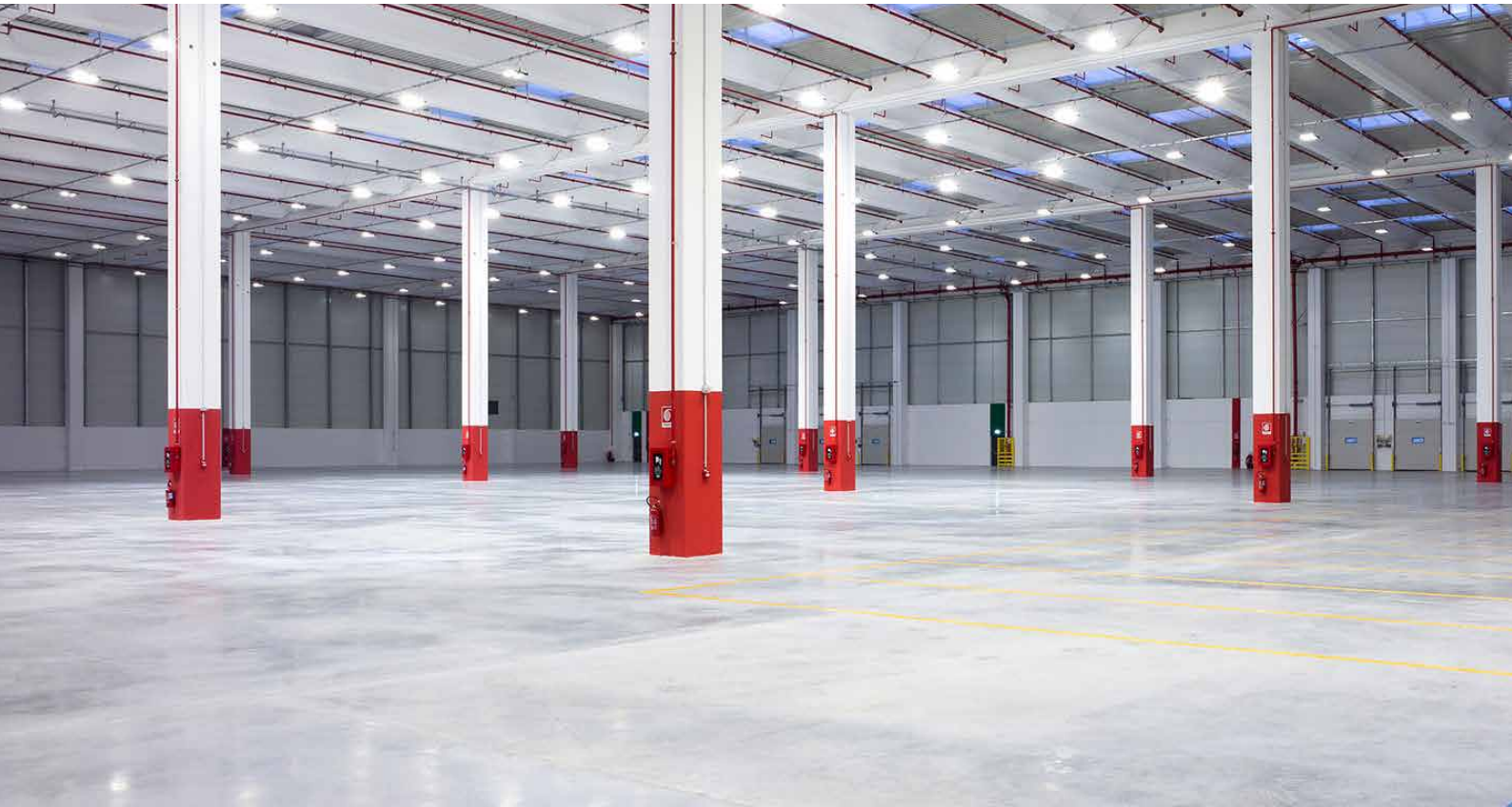

LIGHT DISTRIBUTIONS

Approximate reference illumination diagrams

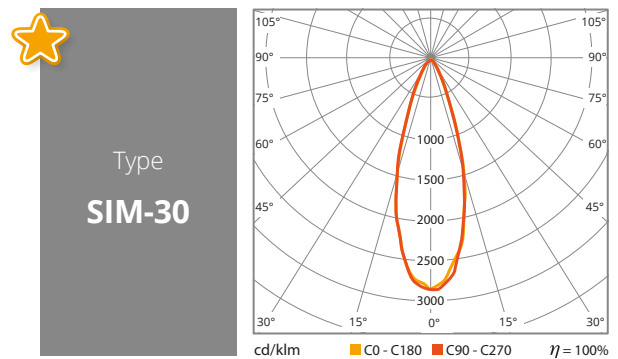
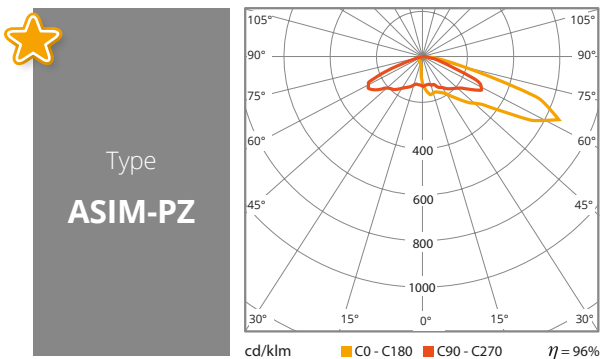
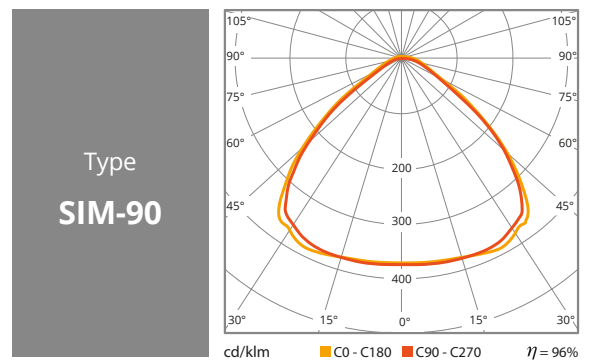
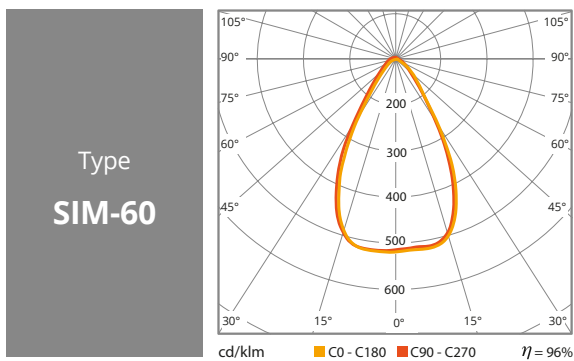

LAMPS

NEW ORNAMENTAL LUMINAIRES



New models of **LAMPS** with lighting technologies newer and more efficient.

With an easy mount and replacement their use is not limited to specific areas, they can light streets, avenues, parks, residential areas, squares, recreational areas...

ADVANTAGES

- **WIDE RANGE OF COLOUR TEMPERATURES**
From ultra warm white to cool white
 - 3,000, 4,000 or 5,000K
 - ★ **2,200K** (Ultra warm white)
- **QUICK MAINTENANCE AND WITHOUT NEEDING TO TOOLS .**
Design optimised to perform whatever maintenance quickly and without needing to use tools.
- **DIMMING OR LIGHTING LEVEL CONTROL**
Optimizes energy savings.
- **CLASS II**
No need for grounding connection.
- **SELV**
Output voltage under 60V.
- **L80 B10**
Estimated luminaire life >100,000 hours for a working environment temperature of 25 °C.
- **POLYCARBONATE DIFFUSERS**
Possibility of incorporating opal or clear polycarbonate diffusers for a better visual comfort.
- **IP68 CONNECTOR – PLUG & PLAY**
They are delivered with tubular connector IP68 for the quick and secure installation of the luminaire.
- **DRIVER, OPTIC GROUP AND IP67 CONNECTIONS**
They offer integral protection to all optic and electronic elements against water and dust .
- **POWDER POLYESTER ELECTROSTATIC PAINTING**
Average thickness 90µV ±10µ.
- **MANUFACTURED IN ALUMINIUM ALLOY DIE CASTING**
Light in weight. Making them easier to assemble.
- **COLLAPSIBLE TOP**
For access to the driver and to the module LED.
- **ALUMINIUM 6063 T5 ANODIZED HEAT SINK**
It guarantees excellent thermal management of the modules LED.

CHARACTERISTICS

- **DRIVERS TELEVES.**
- Constant output current to each module LED 650mA.
- **OPEN CIRCUIT, SURGE AND OVERHEATING PROTECTION.**
- **ELECTRIC DISCHARGE PROTECTION.**
- **TOTAL LUMINAIRE EFFICIENCY TO 120 LUMEN/W.**
- Power factor **PF>0.95.**
- 220-240VAC 50Hz Input voltage.
- **HIGH EFFICIENCY.**
- Operating temperature -15 a +40 °C.

LAMPS NEW ORNAMENTAL LUMINAIRES

LAMPS VILLA



DIMMING OR AUTONOMOUS LIGHTING CONTROL

We have a standalone dimming solution, consisting of a pre-programmed controller on each lamppost.

More information on page19 (**ATMOS**LED Series).

CRI = 70* - CCT=2,200 / 2,700 / 3,000 / 4,000 / 5,000K - FHS<0.1% - PF>0.95

LAMPS VILLA	REFERENCES ⁽¹⁾	N° LEDs	WEIGHT	L	OPERATING CURRENT	TOTAL POWER CONSUMPTION [±8%]	LUMINOUS FLUX (4.000K)	WORKING LIFE ⁽²⁾
			(kg)	(mm)	(mA)	(W)	(lm)	(h)
31W	630701xxxxxxxx	12	9.5	410x815	700	31	3,720 without diffuser	>100,000
39W	630711xxxxxxxx	12	9.5	410x815	500	39	4,956 without diffuser	>100,000
57W	631701xxxxxxxx	24	10.3	410x815	700	57	6,930 without diffuser	>100,000

- Working environment temperature should be in the -15 to 40°C range.

* On demand: CRI>80.

(1) Reference breakdown example: page 50.

(2) L80 B10 A 25°C for a working environment temperature of 25°C.

Estimated working life of the luminaire:

L: Luminous flux maintenance.

B: Probability of luminous flux loss

LxBy for a given number of hours and a given ambient temperature 25°C.

Indicates the time when the flux level of y% of the LED population used for a given type of luminaire is likely to be below x%.



LAMPS FERNANDINA



DIMMING OR AUTONOMOUS LIGHTING CONTROL

We have a standalone dimming solution, consisting of a pre-programmed controller on each lamppost.

More information on page 19 (**ATMOS** LED Series)..

CRI = 70* - CCT=2.200 / 2.700 / 3.000 / 4.000 / 5.000K - FHS<0,1% - PF>0,95

LAMPS FERNANDINA	REFERENCES ⁽¹⁾	N° LEDs	WEIGHT	L	OPERATING CURRENT	TOTAL POWER CONSUMPTION [±8%]	LUMINOUS FLUX (4.000K)	WORKING LIFE ⁽²⁾
			(kg)	(mm)	(mA)	(W)	(lm)	(h)
31W	630702xxxxxxx	12	13.7	850x520	700	31	3,600 without diffuser	>100, 000
★ 39W	630712xxxxxxx	12	13.7	850x520	500	39	4,820 without diffuser	>100,000
57W	631702xxxxxxx	24	14.5	850x520	700	57	6,720 without diffuser	>100,000

- Working environment temperature should be in the -15 to 40°C range.

* On demand: CRI>80.

(1) Reference breakdown example: page 50.

(2) L80 B10 A 25°C for a working environment temperature of 25°C.

Estimated working life of the luminaire:

L: Luminous flux maintenance.

B: Probability of luminous flux loss

LxBy for a given number of hours and a given ambient temperature 25°C.

Indicates the time when the flux level of y% of the LED population used for a given type of luminaire is likely to be below x%.





LAMPS NEW ORNAMENTAL LUMINAIRES

LIGHT DISTRIBUTIONS

Approximate reference illumination diagrams

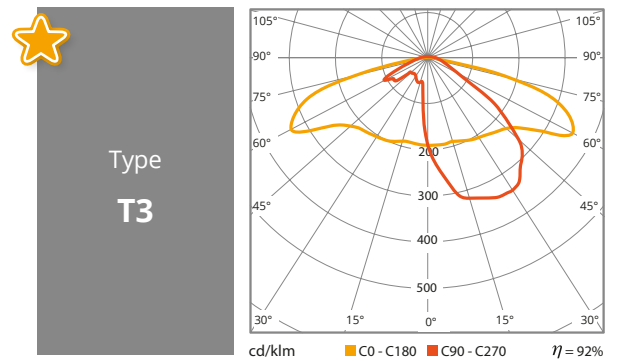
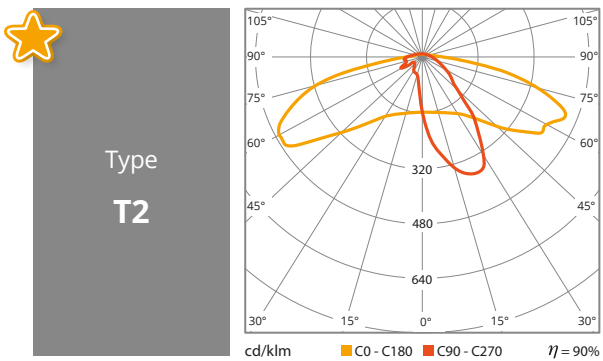
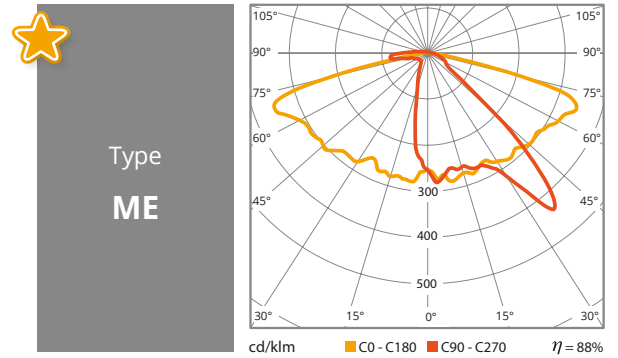
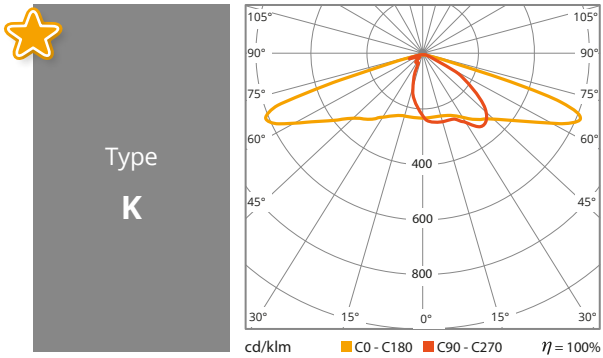
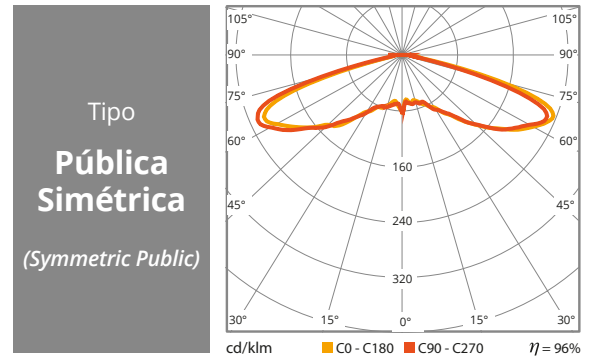
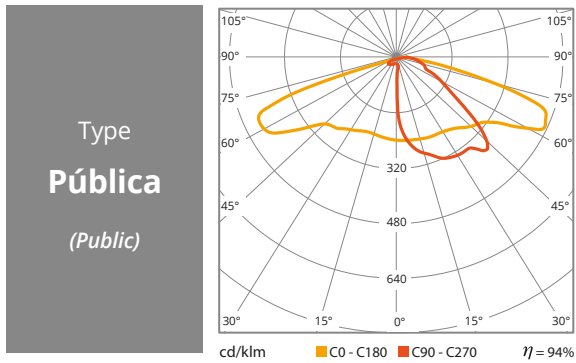

REGULATION

EN 60598-1:2015 + A1:2018
EN 60598-2-3:2003 + A1:2011
EN 62471:2008

EN 62031:2008 + A1:2013 + A2:2015
EN 62493:2015
EN 55015:2013 + A1:2015

EN 61547:2009
EN 61000-3-2:2014
EN 61000-3-3:2013

TESTS PERFORMED
IN A LABORATORY
CERTIFIED BY A
ACCREDITED ENTITY
IN EUROPE



RETROFIT

CHANGE TO LED LIGHTING



RETROFIT is the direct replacement of old lighting technologies with newer, more efficient ones, using previous installations.

This lighting system is appropriate in cases where a balance is required between taking advantage of the new lighting technologies and making the most out of existing resources, thus achieving significant implementation savings.

ADVANTAGES

- **WIDE RANGE OF COLOUR TEMPERATURES**
From ultra warm white to cool white
- 3,000, 4,000 or 5,000K
- ★ **2,200K** (Ultra warm white)
- **INDIVIDUAL OUTPUTS FOR EACH LED CIRCUIT**
They ensure the same current flows across all LEDs at all times.
- **DIMMING OR LIGHTING LEVEL CONTROL**
Optimizes energy savings.
- **LIGHT POLLUTION PREVENTION**
No light is emitted to the upper hemisphere.
- **MULTIPLE MOUNTING OPTIONS**
It can be installed in virtually any existing luminaire, thanks to the four adaptable frames.
- **VERSATILE FINISH**
Multiple finishes, optionally in anodized aluminium or lacquered in any colour in the RAL range.

CHARACTERISTICS

- Adaptable to any classical shape luminaire.
- **LED**, an efficiency **up to 190 lumen/W**.
- Sealed **IP67** optical part.
- LED module protection up to **IK10**
- **Multiple photometric distributions**
- **6063 T5 aluminium anodized sink**, to ensure an appropriate system thermal management.
- **SELV** output voltage. Ensures safety regardless of the quality of the installations.
- **Class II** electric insulation.
- **Total module efficiency**, taking into account the losses in the drivers, **reaches 140 lumen/W**.
- Optionally, they can be manufactured in anodized aluminium or lacquered in any colour in the RAL range..
- Power factor **PF > 0.95**.
- Optionally, the base plate can be custom adjusted.
- Equipped with overheating protection.

RETROFIT CHANGE TO LED LIGHTING

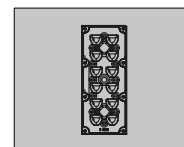
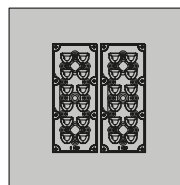
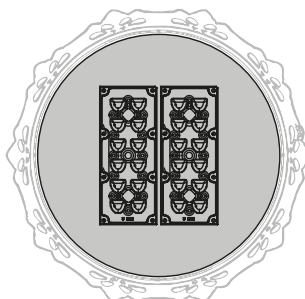

CRI = 70* - CCT=2,200 / 2,700 / 3,000 / 4,000 / 5,000K - FHS<0.1% - PF>0.95

RETROFIT	REFERENCES ⁽¹⁾	No. LEDs	WEIGHT	L	OPERATING CURRENT	TOTAL POWER CONSUMPTION [±8%]	LUMINOUS FLUX (T ^a 40°C)	WORKING LIFE ⁽²⁾
			(kg)	(mm)	(mA)	(W)	(lm)	(h)
31W	630500xxxxxxx	12	1.8	278	700	31	3,875	>100,000
39W	630511xxxxxxx	12	1.8	278	500	39	5,600	>100,000
57W	631500xxxxxxx	24	2.75	296	700	57	7,125	>100,000

- Working environment temperature should be in the -15 to 40°C range.

* On demand: CRI>80.

(1) Reference breakdown example: page 50.

(2) L80 B10 A 25°C for a working environment temperature of 25°C.

Estimated working life of the luminaire:

L: Luminous flux maintenance.

B: Probability of luminous flux loss

LxBy for a given number of hours and a given ambient temperature 25°C.

Indicates the time when the flux level of y% of the LED population used for a given type of luminaire is likely to be below x%.





DIMMING OR AUTONOMOUS LIGHTING CONTROL

We have a standalone dimming solution, consisting of a pre-programmed controller on each lamppost.

More information on page 19 (**ATMOS**LED Series).

REMOTE CONTROL OPTION

Range with flexibility to be installed with point-to-point connectivity nodes

More information on page 18 (Serie **ATMOS**LED N).

RETROFIT ACCESSORIES

For the **RETROFIT** to be carried out, a frame appropriate for the specific lamppost type is required.

Frame for "Fernandina" lamppost

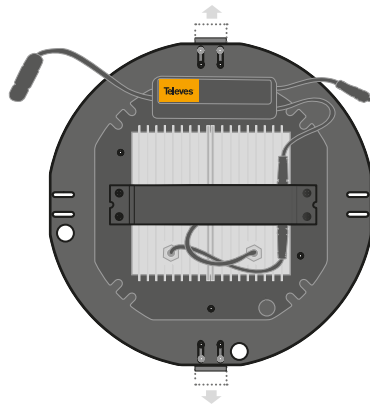

Adaptable frame

- ▲ 6902020010 (290 x 326mm)
- 6902020020 (326 x 353mm)
- 6902020030 (353 x 395mm)
- 6902020040 (371 x 412mm)
- 6902020050 (412 x 454mm)

Frame for "Villa" lamppost

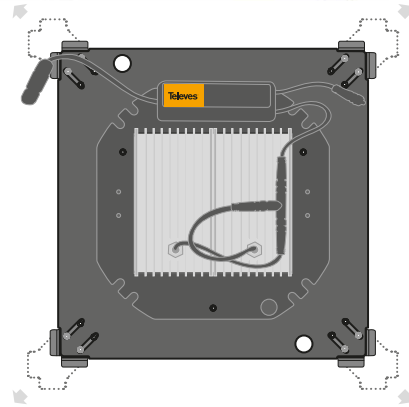

Adaptable frame

- ▲ 6902010010 (290 x 326mm)
- 6902010020 (326 x 353mm)
- 6902010030 (353 x 395mm)
- 6902010040 (371 x 412mm)
- 6902010050 (412 x 454mm)



RETROFIT CHANGE TO LED LIGHTING

LIGHT DISTRIBUTIONS

Approximate reference illumination diagrams

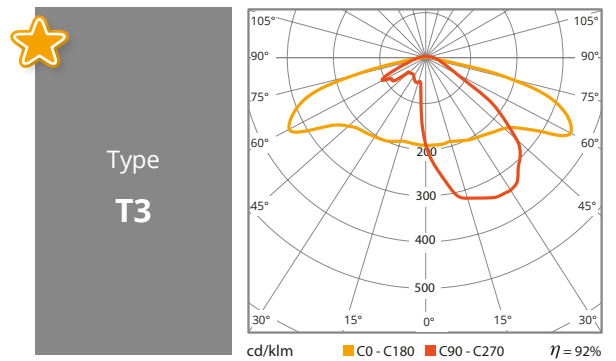
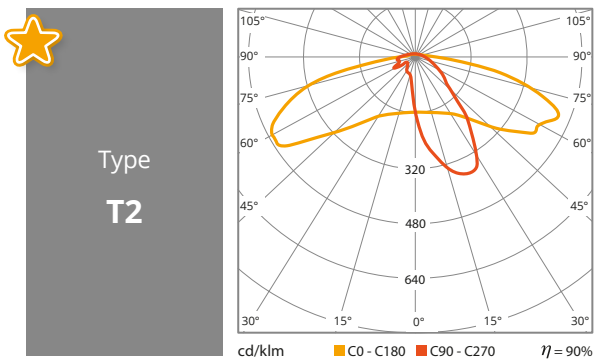
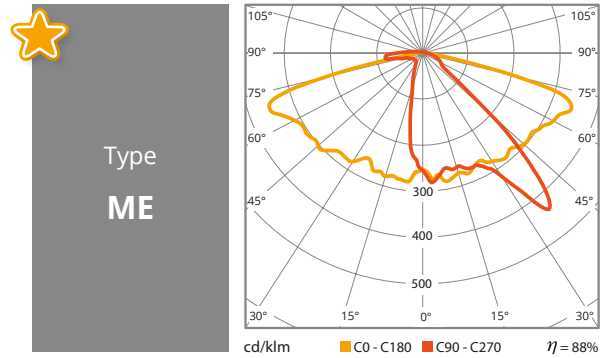
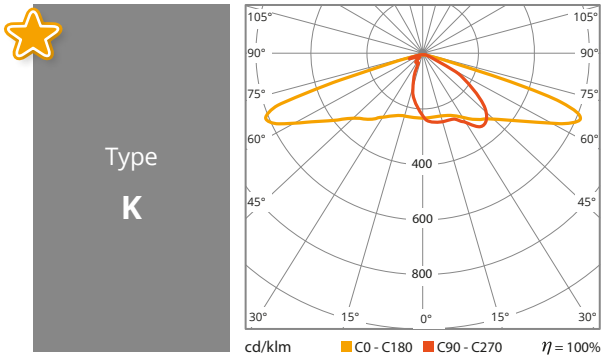
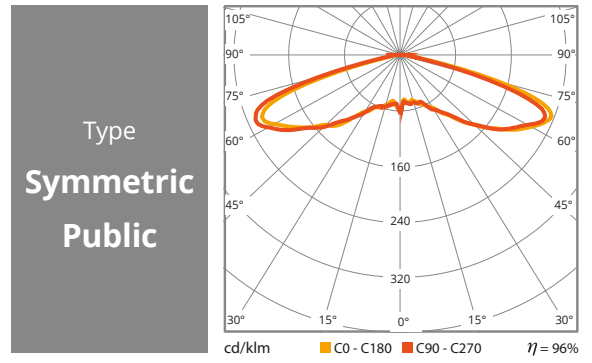
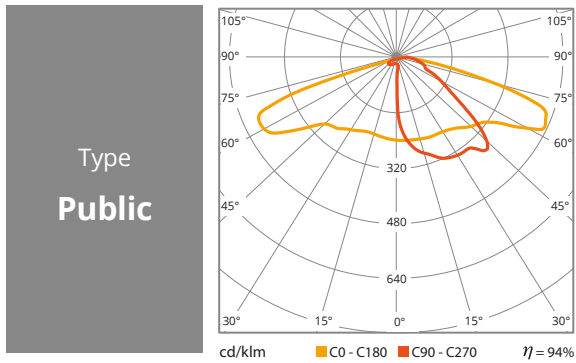

REGULATION

EN 62471:2008
EN 62031:2008 + A1:2013 + A2:2015
EN 62493:2015

EN 55015:2013 + A1:2015
EN 61547:2009
EN 61000-3-2:2014
EN 61000-3-3:2013

TESTS PERFORMED IN A
LABORATORY CERTIFIED
BY A ACCREDITED
ENTITY IN EUROPE





LED FLOODLIGHTS

OUTDOOR AND INDOOR LED LIGHTING



FLOODLIGHTS. The ideal range for areas where the light management and addressing accurately is important.

This lighting system offer a perfect efficiency for any types of sports areas and large areas, from stadiums and big areas to small enclosures.

ADVANTAGES

■ WIDE RANGE OF COLOUR TEMPERATURES

From ultra warm white to cool white

- 3,000, 4,000 or 5,000K
(On demand 2,200 - 8,000K).

■ MINIMIZES MAINTENANCE COSTS

Long workin life.

■ WIDE RANTE OF OPERATING TEMPERATURES

Floodlights: from -20°C to 40°C.

MAXI Floodlights: from -30°C to 40°C.

■ MULTIPLE MOUNTING OPTION

Can be adapted to multiple anchoring systems and positions. Available accesories

■ QUICK RETURN ON INVESTMENT

■ LONG WORKING LIFE

L80B10 ≥ 100,000h.

■ EASY CONNECTION

No need open the luminaire for its installation

CHARACTERISTICS

- **LED** efficiency **up to 190 lumen/W**.

- **IP67**.

- **IK10** protection.

- **Multiple photometric distributions**.

- **6063 T5 aluminium anodized**, to ensure an appropriate system thermal management.

- **Total module efficiency**, taking into account the losses in the drivers **reaches 150 lumen/W**.

- **Class I** electric insulation (MAXI Floodlights).

- **Class II** electric insulation (Floodlights).

- Optionally, lacquered in any colour in the RAL range.

- Power factor **PF>0.95**.

- Equipped with overheating protection



FLOODLIGHTS OUTDOOR AND INDOOR LED LIGHTING

FLOODLIGHTS



69000801

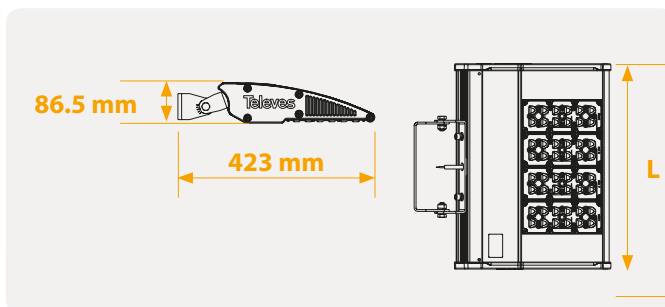

CRI = 70* - CCT=2,200 / 2,700 / 3,000 / 4,000 / 5,000K - FHS<0.1% - PF>0.95

FLOODLIGHTS	REFERENCES (1)	No. LEDs	WEIGHT	L	OPERATING CURRENT	TOTAL POWER CONSUMPTION [±8%]	LUMINOUS FLUX (4,000K)	WORKING LIFE (2)
			(kg)	(mm)	(mA)	(W)	(lm)	(h)
58W	671000xxxxxxx	24	7	340	700	58	8,968	>100,000
100W	673000xxxxxxx	48	9,4	388	700	100	15,984	>100,000

- Working environment temperature should be in the -20° to 40°C range.
 * On demand : CRI > 80.
 (1) Reference breakdown example: page 50.
 (2) L80 B10 A 25°C for a working environment temperature of 25°C.

Estimated working life of the luminaire:
 L: Luminous flux maintenance.
 B: Probability of luminous flux loss.

LxBy for a given number of hours and a given ambient temperature, usually 25°C.
 Indicates the time when the flux level of y% of the LED population used for a given type of luminaire is likely to be below x%.



LIGHT DISTRIBUTIONS

Approximate reference illumination diagrams

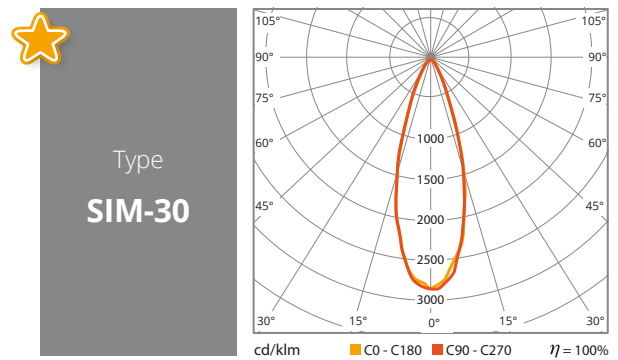
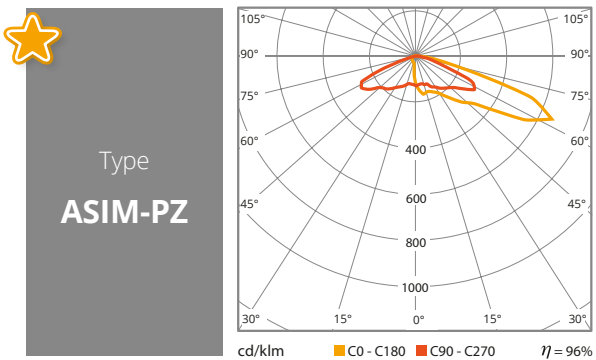
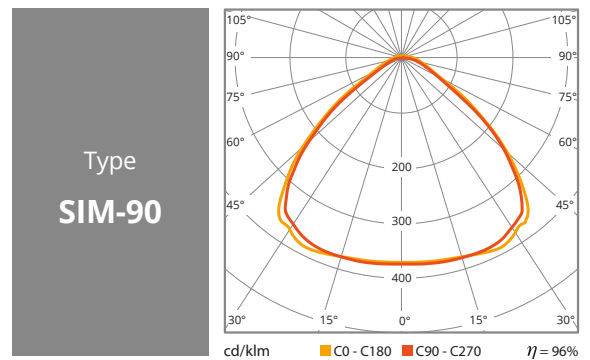
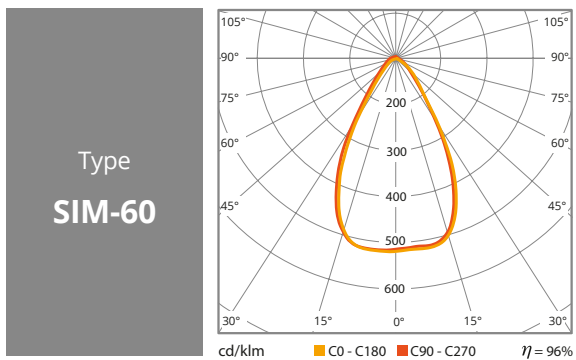

FLOODLIGHTS OUTDOOR AND INDOOR LED LIGHTING

MAXI FLOODLIGHTS



CRI = 70* - CCT=2,200 / 2,700 / 3,000 / 4,000 / 5,000K - FHS<0.1% - PF>0.95

MAXI FLOODLIGHTS	REFERENCES ⁽¹⁾	No. LEDs	WEIGHT	L	OPERATING CURRENT	TOTAL POWER CONSUMPTION [±8%]	LUMINOUS FLUX (4,000K)	WORKING LIFE ⁽²⁾
			(kg)	(mm)	(mA)	(W)	(lm)	(h)
150W	673100xxxxxxx	48	6,9	330	500	150	22,500	>100,000
196W	675100xxxxxxx	72	8,5	405	450	196	29,400	>100,000

- Working environment temperature should be in the -20° to 40°C range.

* On demand : CRI > 80.

(1) Reference breakdown example: page 50.

(2) L80 B10 A 25°C for a working environment temperature of 25°C.

Estimated working life of the luminaire:

L: Luminous flux maintenance.

B: Probability of luminous flux loss.

LxBy for a given number of hours and a given ambient temperature, usually 25°C.

Indicates the time when the flux level of y% of the LED population used for a given type of luminaire is likely to be below x%.

LIGHT DISTRIBUTIONS

Approximate reference illumination diagrams

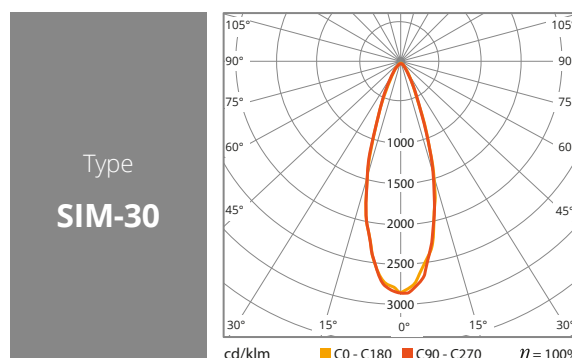
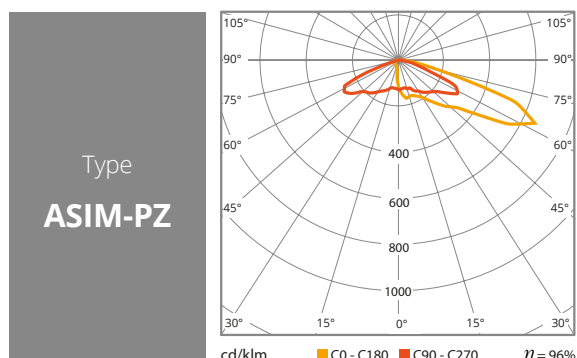
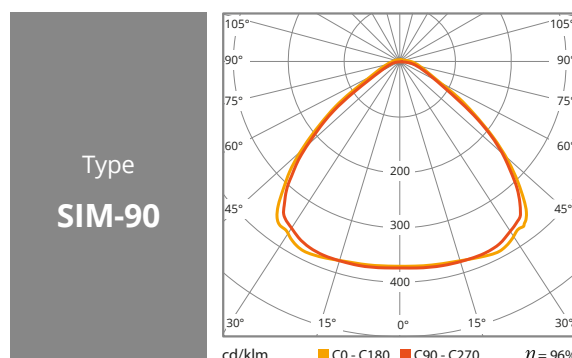
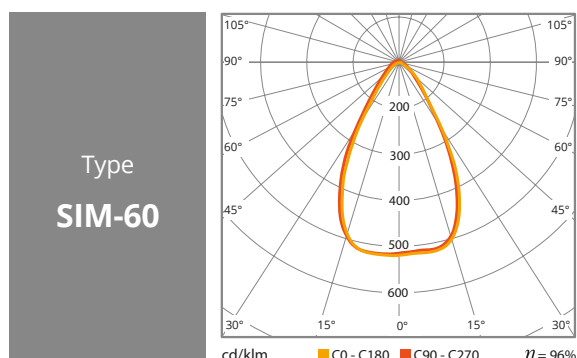

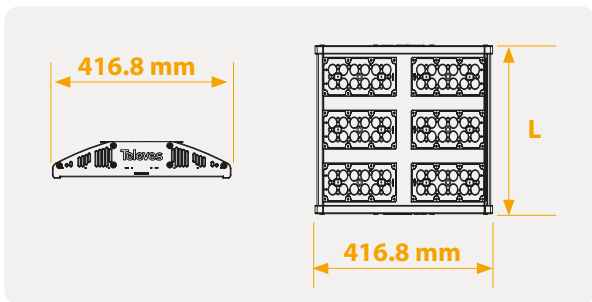

MOUNTING OPTIONS

EMBEDDED SUPPORT



▲ 690101

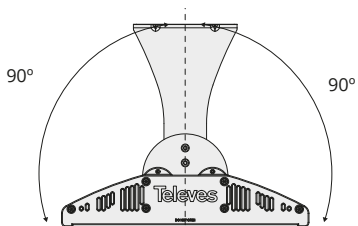

WALL SUPPORT



▲ 69030101 (Floodlight 48 LEDs)
69030201 (Floodlight 72 LEDs)

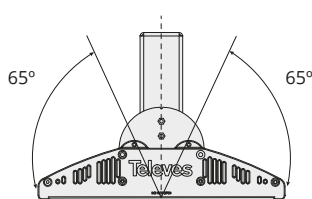

CROSS SUPPORT



▲ 69030301 (Floodlight 48 LEDs)
69030401 (Floodlight 72 LEDs)

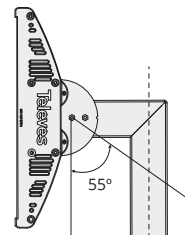

FLOODLIGHTS OUTDOOR AND INDOOR LED LIGHTING

APPLICATION EXAMPLES

The Televés Maxi Floodlights are a large investment in order to optimise sport facilities powerfully.

Their high performance and range of lenses allow us to meet the regulatory requirements of this type of installations with the lowest energy consumption.

PADDLE TENNIS COURT (OUTDOOR)

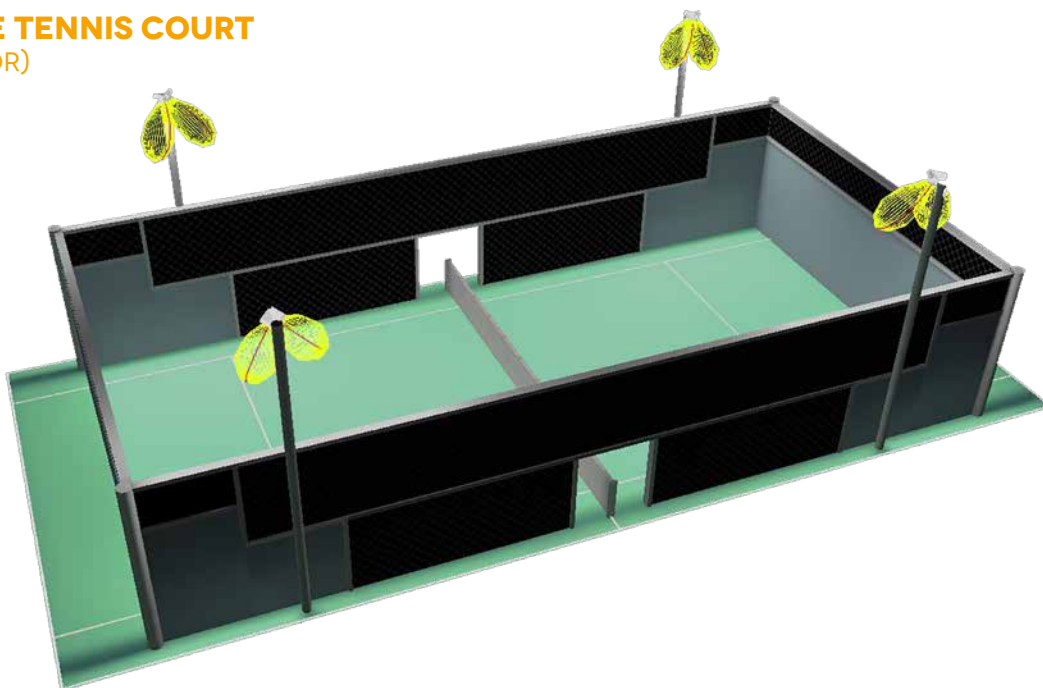

CLASS III

- Local competitions, training, amateur and academic use
- Average efficiency: 200 lux
- Average uniformity: 0.5
- No. of floodlights: 4 (200W)

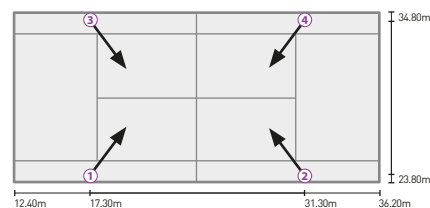

CLASS II

- Regional competitions, high level training
- Average efficiency: 300 lux
- Average uniformity: 0.7
- No. of floodlights: 8 (150W)

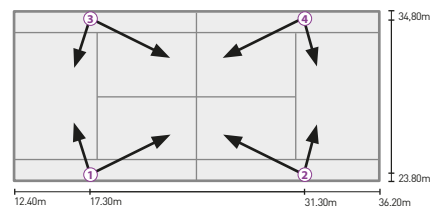

CLASS I

- National and international competitions
- Average efficiency: 500 lux
- Average uniformity: 0.7
- No. of floodlights: 8 (200W)

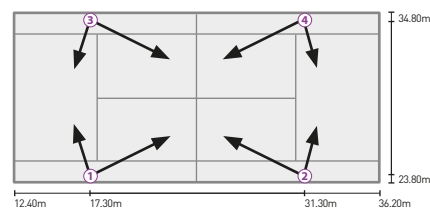

TENNIS COURT (OUTDOOR)



CLASS III

- Local competitions, training, amateur and academic use
- Average efficiency: 200 lux
- Average uniformity: 0.6
- No. of floodlights: 12 (200W)

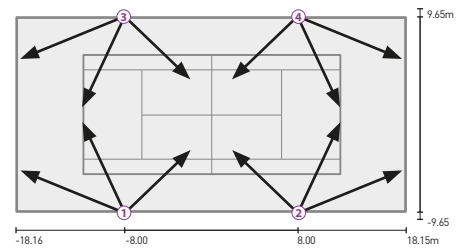

CLASS II

- Regional competitions, high level training
- Average efficiency: 300 lux
- Average uniformity: 0.7
- No. of floodlights: 16 (200W)

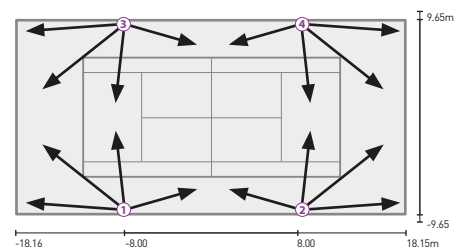

CLASS I

- National and international competitions
- Average efficiency: 500 lux
- Average uniformity: 0.7
- No. of floodlights: 28 (200W)

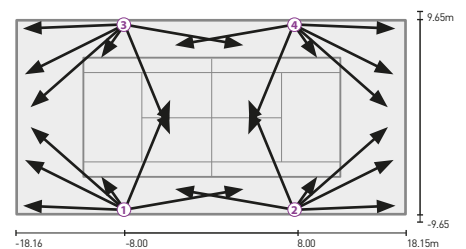

PATHLED

BEACONS



CHARACTERISTICS

- 12 LEDs beacon for path and pedestrian areas' lighting.
- Made of an extruded lacquered aluminium profile, RAL 7011 grey colour.
- Two heights available: 300 and 500 mm.
- Tightness of the optical block: IP65.
- Nominal voltage: 220 - 240 VAC.
- Working temperature: -20 - 35 °C.
- Upper hemispherical flux < 0.1%.
- Power factor > 0.95.
- Colour temperature: 3,000 or 4,000 K.



CRI = 70* - CCT=2,200 / 2,700 / 3,000 / 4,000 / 5,000K

PATHLED	No. of LEDs	WEIGHT (kg)	L (mm)	OPERATING CURRENT (mA)	VOLTAGE (V)	POWER [±8%] (W)	LUMINOUS FLUX (lm)
	12	4.32	300 / 500	300	36	12.5	1,555.2

* On demand : CRI > 80.

LIGHT DISTRIBUTIONS

Approximate reference illumination diagrams

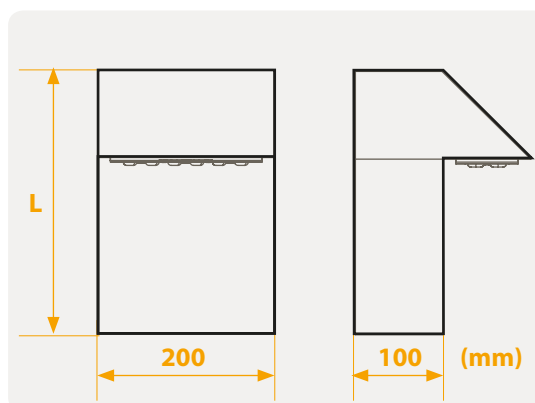
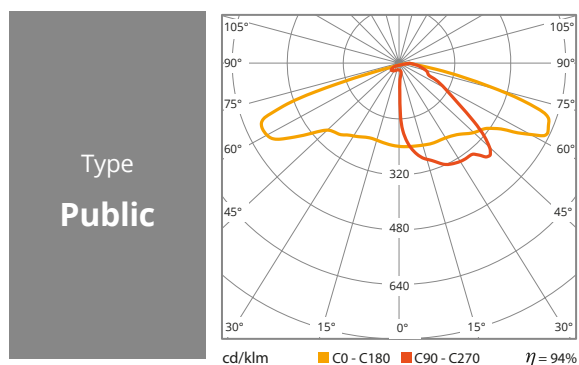

REFERENCE BREAKDOWN EXAMPLE

680500 01 30 01 01

Series

680500

Dimming

01

Colour Temp.

30

Optics

01

Chassis

01

Possible values

ATMOSLED 5

601500	ATMOSLED 5 24 LED 39W
602500	ATMOSLED 5 36 LED 58W
603500	ATMOSLED 5 48 LED 80W
604500	ATMOSLED 5 60 LED 95W
605500	ATMOSLED 5 72 LED 120W

ATMOSLED 7

610500	ATMOSLED 7 12 LED 26W
611500	ATMOSLED 7 24 LED 58W
612500	ATMOSLED 7 36 LED 85W
613500	ATMOSLED 7 48 LED 100W

ATMOSLED N

680500	ATMOSLED N 12 LED 39W
681500	ATMOSLED N 24 LED 58W
682500	ATMOSLED N 36 LED 78W
683500	ATMOSLED N 48 LED 108W

ATMOSLED E

680300	ATMOSLED E 12 LED 39W
681300	ATMOSLED E 24 LED 58W
682300	ATMOSLED E 36 LED 78W
683300	ATMOSLED E 48 LED 108W

INNERLED

623500	INNERLED 48 LED 80W
625500	INNERLED 72 LED 130W
627500	INNERLED 96 LED 210W

LAMPS

630701	LAMP VILLA 12 LED 31W
630711	LAMP VILLA 12 LED 39W
630702	LAMP FERNANDINA 12 LED 31W
630712	LAMP FERNANDINA 12 LED 39W
631701	LAMP VILLA 24 LED 57W
631702	LAMP FERNANDINA 24 LED 57W

RETROFIT

630500	RETROFIT 12 LED 31W
630511	RETROFIT 12 LED 39W
631500	RETROFIT 24 LED 57W

FLOODLIGHTS

671000	FLOODLIGHT 24 LED 58W
673000	FLOODLIGHT 48 LED 100W
673100	FLOODLIGHT MAXI 48 LED 150W
675100	FLOODLIGHT MAXI 72 LED 196W

00	-
01	Dimming

22	2.200K
27	2.700K
30	3.000K
40	4.000K
50	5.000K

01	P
02	SP
03	S90
04	S60
05	K
06	T2
07	ME
08	T3
09	PZ
10	S30

01	Standard
XX	Custom

680500 01 30 01 01

The last 8 digits of each reference will depend on the requested configuration for the luminaire.

Taking account of the Dimming, the colour temperature, the optic and the chassis where the luminaire is mounted as well as the chassis colour.



PASSION for QUALITY

SPAIN (HEAD OFFICE) 🇪🇸

Televes S.A.U.
Rúa B. de Conxo, 17
15706 Santiago de Compostela
42° 51' 43.6212" N, 8° 33' 27.702" W
T. +34 981522200
F. +34 981522262
televes@televes.com

BARCELONA

Carrer Sant Ferrán, 27
08940 Cornellà de Llobregat (Barcelona)
41° 21' 9.054" N, 2° 5' 7.8324" E
T. +34 902686415
F. +34 934745006
barcelona@televes.com

LAS PALMAS

Gral. Mas de Gaminde, 26
35006 Las Palmas
28° 7' 55.884" N, 15° 26' 1.356" W
T. +34 902686407
F. +34 928231366
laspalmas@televes.com

MADRID

Paseo los Pontones, 11
28005 Madrid
40° 24' 22.5576" N, 3° 42' 46.35" W
T. +34 902686416
F. +34 914745421
madrid@televes.com

FRANCE

Televes France SAS
1 Rue Louis de Broglie
Parc d'Activités de l'Esplanade
77400 St. Thibault des Vignes (FRANCE)
48° 51' 48.5136" N, 2° 40' 26.0724" E
T. +33 0 1 60 359 210
F. +33 0 1 60 359 040
televes.fr@televes.com

GERMANY

Televes Deutschland GmbH
Küferstraße 20,
73257 Köngen (GERMANY)
48° 40' 42.0168" N, 9° 22' 25.932" E
T. +49 70 244 6860
F. +49 70 246 295
televes.de@televes.com

ITALY

Televes Italia S.r.l.
S. op. Viale Liguria 16,
20068 Peschiera Borromeo (MI) (ITALY)
45° 25' 53.3784" N, 9° 19' 25.3272" E
T. +39 02 516 50604 (RA)
F. +39 02 553 07363
televes.it@televes.com

POLAND

Televes Polska Sp. z o.o.
ul. Jana Długosza 48,
51-162 Wrocław (POLAND)
51° 7' 59.8224" N, 17° 3' 42.8256" E
T. +48 71 790 1115
F. +48 71 790 1112
televes.polska@televes.com

PORTUGAL 🇵🇹

Televes Electrónica Portuguesa Lda.
Via Dr. Francisco Sá Carneiro. Lote 17.
Zona Ind. Maia 1. Sector-X.
4470-518 Barca, Maia (PORTUGAL)
41° 14' 58.344" N, 8° 37' 48.2196" O
T. +351 22 947 8900
F. +351 22 948 8719
GSM +351 96 858 1614
televes.pt@televes.com

LISBOA

Rua Augusto Gil, 21A.
1000-518 Lisboa
38° 44' 38" N, 09° 08' 27" O
T. +351 21 793 2537
F. +351 21 793 2418
televes.lisboa@televes.com

RUSSIA

Televes RUSS.
Volokolamskoye shosse, 142, str.6, 603, 617
125464 Moscow (RUSSIA)
55° 49' 46.05" N, 37° 22' 16.45" E
T. +7 495 107 90 95
F. +7 495 107 90 96
televes.russ@televes.com

SCANDINAVIA

Televes Scandinavia AB.
Vannhögsgatan 7,
231 66 Trelleborg (SWEDEN)
55° 23' 05.7" N, 13° 08' 42.3" E
T. +46 410 36 36 00
F. +46 410 36 36 01
televes.sc@televes.com

UNITED ARAB EMIRATES

Televes Middle East FZE
P.O. Box 17199
Jebel Ali Free Zone Dubai (UAE)
24° 57' 39.7548" N, 55° 3' 48.8232" E
T. +971 4 88 34 344
F. +971 4 88 34 644
televes.me@televes.com

UNITED KINGDOM

Televes United Kingdom Ltd.
Unit 11 Hill Street, Industrial Estate
Cwmbran, Gwent NP44 7PG (UK)
51° 38' 34.8144" N, 3° 1' 23.88" W
T. +44 01 633 875 821
F. +44 01 633 866 311
televes.uk@televes.com

USA

Televes USA LLC.
1385 S Colorado Blvd, Suite A-108
Denver, CO 80222 (USA)
39° 691527" N, 104° 941206" W
T. +1 303 256 6767
televes.usa@televes.com

CHINA

Televes Trade (Shanghai) Co., Ltd.
Unit 207-208, Building A, No 374
Wukang Rd, Xuhui District Shanghai
P.R.C. 200031 (CHINA)
31° 12' 23.5692" N, 121° 26' 21.9804" E
T. +86 21 6126 7620
F. +86 21 6466 6431
shanghai@televes.com.cn



BOUND BY TECHNOLOGY

Teledes Corporation is at the heart of a group of technological companies representing global leadership in design and development of equipment for all types of telecom infrastructures in cities, buildings and homes.

Teledes Corporation groups more than 20 companies that work together pursuing the common goal of designing, developing and manufacturing in Spain high quality products and solutions for various sectors in the field of telecommunications, such as transmission and distribution of television services, implementation of multiservice networks in Hospitality, development of advanced eHealth platforms, as well as integrating solutions for professional LED lighting projects.

Teledes Corporation reaches over 100 countries directly through its 11 international subsidiaries (España, Portugal, France, United Kingdom, United Arab Emirates, Italia, United States, Deutschland, China, Polska, Russia, Scandinavia) and through an extensive network of professional distributors.